

TARP

3698249
73590001

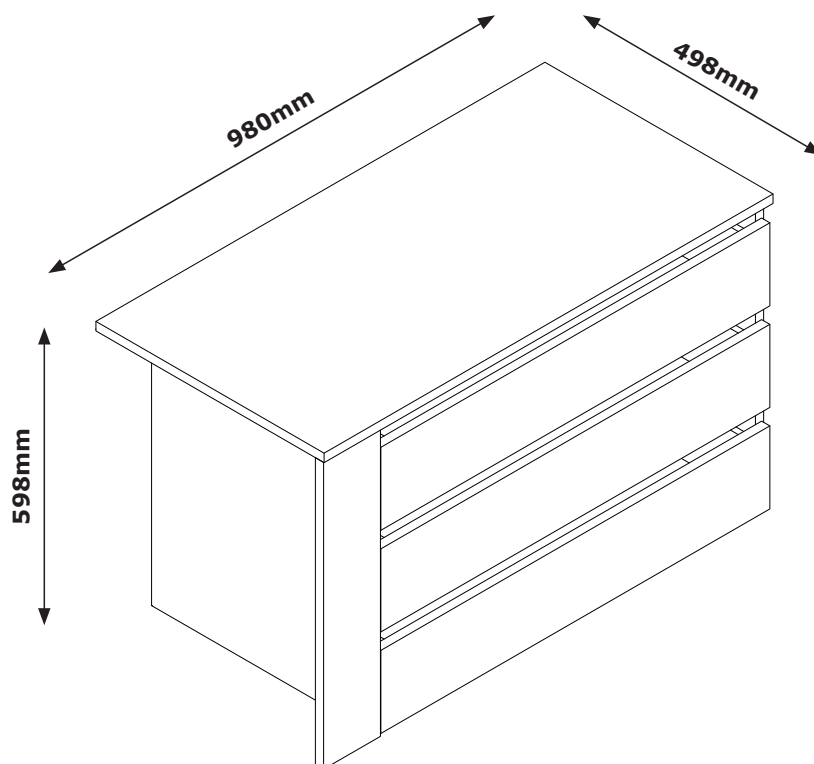

FR
Pensez à
donner ou recycler.

Association ou Magasin ou Déchèterie

<https://quefairedemesdechets.fr>



JYSK.com

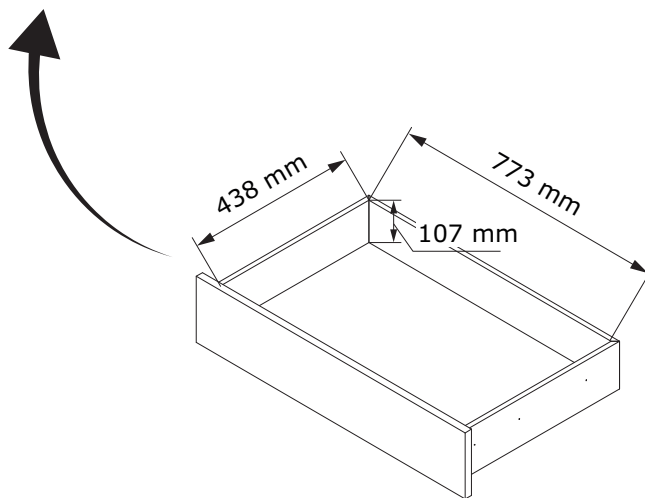
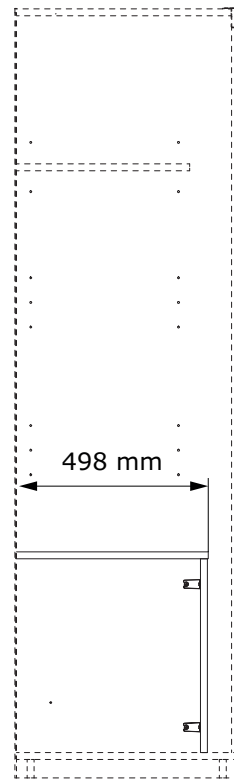
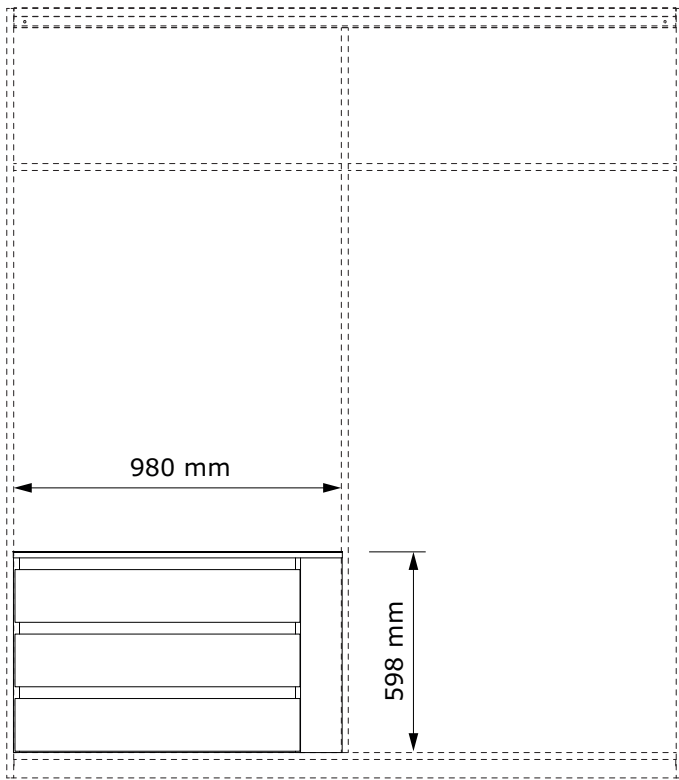
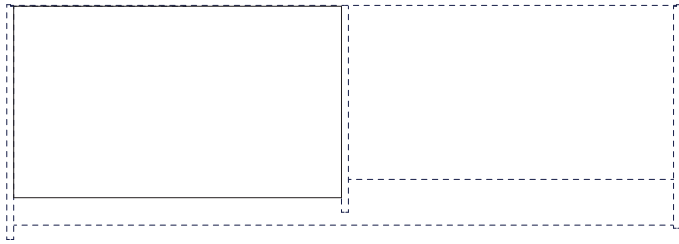

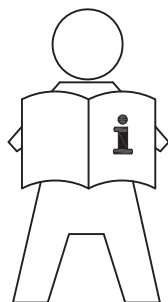

- GB: IMPORTANT INFORMATION!**
Please read the entire manual carefully before starting to assemble and/or using this product. Follow the manual thoroughly and keep it for further reference.
- DK: VIGTIG INFORMATION!**
Læs hele manualen grundigt igennem før samling og/eller brug af dette produkt. Følg manualen nøje, og opbevar den til senere brug.
- DE: WICHTIGE INFORMATIONEN!**
Bitte lesen Sie die gesamte Anleitung sorgfältig durch, bevor Sie mit der Montage und/oder Verwendung dieses Produkts beginnen. Befolgen Sie die Anleitung genau und bewahren Sie diese für den späteren Gebrauch auf.
- NO: VIKTIG INFORMASJON!**
Les hele bruksanvisningen nøye før du begynner å montere og/eller bruke dette produktet. Følg bruksanvisningen nøye, og ta vare på den for fremtidig bruk.
- SE: VIKTIG INFORMATION!**
Läs bruksanvisningen i sin helhet innan du börjar att montera och/eller använda produkten. Följ bruksanvisningen noggrant och spara den för framtida referens.
- FI: TÄRKEITÄ TIETOJA**
Lue käyttöohjeet kokonaan ennen tämän tuotteen kokoamista ja/tai käyttöä. Noudata käyttöohjeita tarkasti ja säilytä ne myöhempää tarvetta varten.
- PL: WAŻNE INFORMACJE.**
Przed użyciem produktu należy dokładnie zapoznać się ze wskazówkami bezpieczeństwa. Należy zapoznać się z instrukcją obsługi i zachować ją do użytku w przyszłości.
- CZ: DŮLEŽITÉ INFORMACE!**
Před sestavením nebo použitím výrobku si pečlivě přečtěte celý návod. Dodržujte důsledně uvedené pokyny a návod uschovejte, aby byl k dispozici v případě potřeby.
- HU: FONTOS INFORMÁCIÓ**
A termék összeszerelésének vagy használatának megkezdése előtt figyelmesen olvassa el a teljes útmutatót. Őrizze meg az útmutatót, és gondosan tartsa be a benne foglaltakat.
- NL: BELANGRIJKE INFORMATIE!**
Lees de volledige handleiding zorgvuldig door voordat u dit product monteert en/of gebruikt. Volg de handleiding zorgvuldig en bewaar deze voor toekomstig gebruik.
- SK: DŔLEŽITÉ INFORMÁCIE!**
Predtým ako začnete s montážou a/alebo používaním tohto produktu si pozorne prečítajte celý návod. Návod dôsledne dodržiavajte a ponechajte si ho pre použitie v budúcnosti.
- FR: INFORMATIONS IMPORTANTES**
Veuillez lire attentivement l'ensemble du manuel avant de commencer à monter et/ou utiliser ce produit. Suivez rigoureusement le manuel et conservez-le pour toute consultation ultérieure.
- SI: POMEMBNE INFORMACIJE!**
Pred montažo/uporabo izdelka pozorno preberite ta navodila za uporabo. Upošteвайте navodila in jih shranite, saj jih boste morda še potrebovali.
- HR: VAŽNE OBAVIJESTI!**
Molimo Vas pažljivo pročitajte upute za uporabu prije sastavljanja i/ili korištenja ovog proizvoda. Strogo se pridržavajte uputa i sačuvajte ih za buduće potrebe.
- IT: INFORMAZIONI IMPORTANTI!**
Si prega di leggere attentamente l'intero manuale prima di cominciare a montare e/o a utilizzare questo prodotto. Seguire rigorosamente le istruzioni di questo manuale e conservarlo per una successiva consultazione.
- ES: INFORMACIÓN IMPORTANTE**
Leer con atención todo el manual antes de comenzar a ensamblar/usar este producto. Seguir a conciencia las instrucciones del manual y conservarlo para futuras consultas.
- BA: VAŽNE INFORMACIJE!**
Prije sklapanja i/ili korištenja ovog proizvoda, pažljivo pročitajte cijeli priručnik. Pažljivo se pridržavajte uputstava u priručniku i sačuvajte ga za buduću upotrebu.
- RS: VAŽNE INFORMACIJE!**
Pažljivo pročitajte kompletan priručnik pre nego što počnete da sklapate i/ili koristite ovaj proizvod. Detaljno sledite priručnik i sačuvajte ga za kasniju upotrebu.
- UA: ВАЖЛИВА ІНФОРМАЦІЯ.**
Уважно прочитайте весь посібник, перш ніж збирати та/чи використовувати цей продукт. Виконайте всі інструкції цього посібника та збережіть його для подальшого використання.
- RO: INFORMAȚII IMPORTANTE**
Citiți cu atenție întregul manual înainte de a începe să montați și/sau să utilizați acest produs. Urmați îndeaproape instrucțiunile din manual și păstrați-l pentru consultare ulterioară.
- BG: ВАЖНА ИНФОРМАЦИЯ!**
Моля, прочетете цялото ръководство внимателно, преди да започнете да сглобявате и/или използвате този продукт. Следвайте стриктно ръководството и го пазете за бъдещи справки.
- GR: ΣΗΜΑΝΤΙΚΕΣ ΠΛΗΡΟΦΟΡΙΕΣ!**
Διαβάστε προσεκτικά ολόκληρο το εγχειρίδιο πριν από τη συναρμολόγηση ή/και τη χρήση του προϊόντος. Ακολουθήστε προσεκτικά τις οδηγίες του εγχειριδίου και κρατήστε τις για μελλοντική αναφορά.
- PT: INFORMAÇÕES IMPORTANTES!**
Queira ler este manual inteiro e com atenção antes de começar a montar e/ou usar este produto. Siga as instruções de forma cuidadosa e guarde-as para referência futura.
- RU: ВАЖНАЯ ИНФОРМАЦИЯ!**
Внимательно и полностью прочитайте это руководство, прежде чем приступить к сборке или использованию этого изделия. Следуйте всем инструкциям этого руководства и сохраните его на будущее для справки.
- TR: ÖNEMLİ BİLGİLER!**
Bu ürünün montajını yapmaya başlamadan ve/veya ürünü kullanmadan önce lütfen kılavuzun tamamını dikkatlice okuyun. Kılavuzu adım adım izleyin ve daha sonra başvurmak üzere saklayın.
- CN: 重要信息!**
组装和/或使用本产品之前请通读该手册。请严格遵循手册说明,保留手册供日后参考。

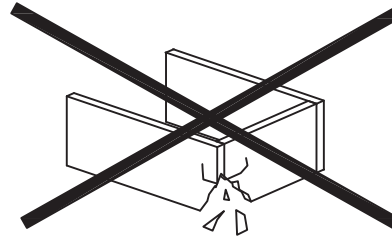
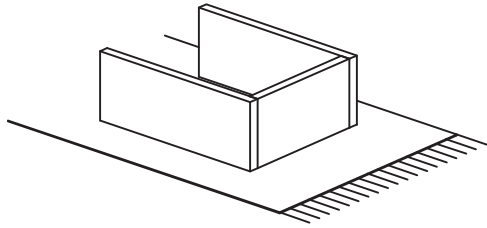

- GB:** **WARNING TO AVOID SCRATCHES!**
In order to avoid scratching this furniture should be assembled on a soft layer - could be a rug.
- DK:** **ADVARSEL FOR AT FORHINDRE RIDSER!**
For at forhindre ridser skal dette møbel samles på et blødt underlag, f.eks. et tæppe.
- DE:** **HINWEIS ZUR VERMEIDUNG VON KRATZERN**
Um Kratzer zu vermeiden, sollte dieses Möbelstück auf einer weichen Unterlage montiert werden (z. B. Teppich).
- NO:** **ADVARSEL FOR Å UNNGÅ RIPER!**
For å unngå ripper må møbelet monteres på et mykt underlag, for eksempel et teppe.
- SE:** **VARNING OM HUR DU UNDVIKER REPOR!**
För att undvika repor ska denna möbel monteras på ett mjukt underlag, exempelvis en matta.
- FI:** **VARO NAARMUJA!**
Varo naarmuja ja kokoa tämä kaluste pehmeällä alustalla, esimerkiksi maton päällä.
- PL:** **OSTRZEŻENIE WS. USZKODZEŃ**
Aby uniknąć rys, ten mebel powinien być montowany, składany na miękkim podłożu, np. dywanie.
- CZ:** **VAROVÁNÍ TÝKAJÍCÍ SE POŠKRÁBÁNÍ!**
Aby nedošlo k poškrábání, sestavujte nábytek na měkkém podkladu – např. na koberci.
- HU:** **KARCOLÁSOK MEGELŐZÉSE – FIGYELEM!**
A karcolások megelőzése érdekében a bútort puha felületen, például szőnyegen kell összeszerelni.
- NL:** **WAARSCHUWING OM KRASSEN TE VERMIJDEN!**
Om te voorkomen dat dit meubel krassen vertoont, moet het gemonteerd worden op een zachte ondergrond - zoals een tapijt
- SK:** **VÝSTRAHA TÝKAJÚCA SA PREDCHÁDZANIA ŠKRABANCOM!**
Aby sa predišlo škrabancom, tento nábytok by sa mal montovať na mäkkom podklade, napríklad na koberci.
- FR:** **AVERTISSEMENT POUR ÉVITER LES RAYURES**
Afin d'éviter les rayures, ce meuble doit être monté sur une surface souple (un tapis, par exemple).
- SI:** **KAKO PREPREČITI PRASKE!**
Da bi se izognili praskam na pohištvu, pohištvu sestavite na mehki podlagi, npr. na preprogi
- HR:** **UPOZORENJE O IZBJEGAVANJU OGREBOTINA!**
Kako bi se izbjegle ogrebotine, ovaj proizvod potrebno je sastavljati na mekanoj površini - primjerice, na tepihu.
- IT:** **AVVERTENZA PER EVITARE I GRAFFII!**
Per evitare i graffi, si raccomanda di montare questo mobile su una superficie morbida (come ad es. un tappeto).
- ES:** **ADVERTENCIA PARA EVITAR RAYADURAS**
Para no rayar este mueble, es aconsejable ensamblarlo sobre una superficie suave (posiblemente una alfombra).
- BA:** **UPOZORENJE ZA SPRJEČAVANJE NASTANKA OGREBOTINA!**
Da bi se izbjegle ogrebotine na ovom namještaju, poželjno ga je sastaviti na mekoj podlozi - na primjer, tepihu.
- RS:** **UPOZORENJE ZA IZBEGAVANJE OGREBOTINA!**
Da biste izbegli ogrebotine, ovaj nameštaj treba da sastavljate na mekoj podlozi - može prostirka.
- UA:** **ПОПЕРЕДЖЕННЯ ЩОДО ПОДРЯПИН.**
Щоб уникнути подряпин, ці меблі слід збирати на м'якій поверхні, наприклад, на килимі.
- RO:** **ATENȚIONARE PENTRU EVITAREA ZGĂRIERII!**
Pentru evitarea zgârierii, această piesă de mobilier trebuie să fie montată pe o suprafață moale, de exemplu, pe un covor.
- BG:** **ПРЕДУПРЕЖДЕНИЕ ЗА ИЗБЯГВАНЕ НА ДРАСКОТИНИ!**
За да избегнете надраскване, тази мебел трябва да бъде сглобена на мека повърхност – например килим.
- GR:** **ΠΡΟΕΙΔΟΠΟΙΗΣΗ ΓΙΑ ΤΗΝ ΑΠΟΦΥΓΗ ΓΡΑΤΣΟΥΝΙΣΜΩΝ!**
Για την αποφυγή γρατσουνιών, το έπιπλο θα πρέπει να συναρμολογηθεί σε μαλακή επιφάνεια, όπως για παράδειγμα πάνω σε ένα χαλί.
- PT:** **AVISO PARA EVITAR RISCOS**
Para evitar riscos, este móvel deve ser montado numa superfície macia (por exemplo, tapete).
- RU:** **ПРЕДУПРЕЖДЕНИЕ ОТНОСИТЕЛЬНО ЦАРАПИН!**
Во избежание нанесения царапин, сборку этой мебели необходимо выполнять на мягкой поверхности, например на ковре.
- TR:** **ÇİZİLMELERİ ÖNLEMENE YÖNELİK UYARI!**
Bu mobilyanın çizilmesini engellemek için montajını halı gibi yumuşak bir yüzeyin üzerinde yapın.
- CN:** **防刮警告!**
为了避免刮伤家具，应在地毯等软面上进行组装。

- GB: IMPORTANT!**
It is important that any product which is assembled using any kind of screw is re-tightened 2 weeks after assembly, and once every 3 months - in order to assure stability through-out the lifespan of the product.
- DK: VIGTIG!**
Det er vigtigt, at alle produkter, der samles med alle former for skruer, efterspændes to uger efter samling samt hver tredje måned for at sikre, at produktet er stabilt i hele dets levetid.
- DE: WICHTIG!**
Es ist wichtig, bei jedem mit Schrauben montierten Produkt diese 2 Wochen nach dem Zusammenbau sowie einmal alle 3 Monate wieder anzuziehen, um die Stabilität des Produkts über die gesamte Lebensdauer hinweg zu gewährleisten.
- NO: VIKTIG!**
Det er viktig at alle produkter som monteres med skruer blir etterstrammet 2 uker etter montering, og hver 3. måned for å sikre stabiliteten gjennom hele produktets levetid
- SE: VIKTIG!**
För alla produkter som monteras med skruv är det viktigt att dessa efterdras två veckor efter monteringen och därefter en gång var tredje månad. Detta för att säkerställa att produkten håller sig stabil under hela sin livslängd.
- FI: TÄRKEÄÄ!**
On tärkeää, että kaikki ruuvien avulla koottavat tuotteet kiristetään uudelleen 2 viikkoa kokoamisen jälkeen ja aina 3 kuukauden välein, jotta tuote pysyy vakaana koko käyttöikänsä ajan.
- PL: WAŻNE!**
Ważne jest, żeby każdy ze skręcanych produktów został ponownie dokręcony w ciągu 2 tygodni od montażu, a następnie sprawdzić co 3 miesiące czy śruby są dokręcone — w celu zapewnienia stabilności przez czas użytkowania produktu.
- CZ: DŮLEŽITÉ!**
U každého výrobku, který se sestavuje pomocí jakýchkoli šroubků, je důležité dotáhnout šroubky 2 týdny po sestavení a potom každé 3 měsíce, aby byla zajištěna stabilita po celou dobu životnosti výrobku.
- HU: FONTOS!**
Minden terméknél fontos, hogy bármilyen fajta csavarral is történi az összeszerelés, utána 2 héttel, majd 3 havi rendszerességgel szükséges a csavarok utánhúzóása. Ezzel a termék teljes élettartamán keresztül biztosítható a stabilitása.
- NL: BELANGRIJK!**
Het is belangrijk om elk product dat met om het even welk soort schroef wordt gemonteerd, twee weken na montage en om de drie maanden, opnieuw wordt vastgeschroefd, om de stabiliteit van het product tijdens de hele levensduur te verzekeren.
- SK: DŮLEŽITÉ!**
Je důležité, aby sa na akomkoľvek produkte, montovanom pomocou akýchkoľvek skrutiek, skrutky dotiahli po dvoch týždňoch od montáže, a jedenkrát v priebehu každých 3 mesiacov – tak sa zaručí stabilita počas celej životnosti produktu.
- FR: IMPORTANT**
Il est important que tout produit monté à l'aide de vis soit resserré 2 semaines après son montage, puis tous les 3 mois, afin de garantir sa stabilité durant tout son cycle de vie.
- SI: POMEMBNO!**
Vsak izdelek, ki ga sestavite z uporabo kakršnihkoli vijakov morate 2 tedna po sestavitvi ponovno pregledati in vijake po potrebi priviti. To ponovite vsake 3 mesece, da bi zagotovili stabilnost izdelka skozi njegovo celotno življenjsko dobo.
- HR: VAŽNO!**
Važno je da se svi tipovi vijaka na bilo kojoj vrsti proizvoda koji se s pomoću njih sastavlja ponovno pritegnu 2 tjedna nakon sastavljanja te jednom svaka 3 mjeseca - kako bi se zajamčila stabilnost tijekom životnog vijeka proizvoda.
- IT: IMPORTANTE!**
È importante in ogni prodotto montato con viti serrare ben strette le viti 2 settimane dopo il montaggio e poi ogni 3 mesi per garantire la sua stabilità durante tutta la durata del prodotto.
- ES: IMPORTANTE**
En el caso de los productos ensamblados, es importante volver a apretar los tornillos 2 semanas después del montaje y después cada 3 meses, para así preservar la estabilidad durante toda la vida útil del producto.
- BA: VAŽNO!**
Za sve proizvode sa vijčanim vezama, potrebno je izvršiti pritezanje 2 sedmice nakon sklapanja i svaka 3 mjeseca nakon toga, kako bi se osigurala stabilnost tokom cijelog životnog vijeka proizvoda.
- RS: VAŽNO!**
Važno je da svaki proizvod koji je sklopljen korišćenjem bilo kakvih šrafova bude ponovo pričvršćen 2 nedelje nakon sklapanja i jednom svaka 3 meseca - kako bi se obezbedila stabilnost tokom celog veka trajanja proizvoda.
- UA: УВАГА.**
Майте на увазі, якщо у процесі монтажу продукту використовуються гвинти будь-якого типу, їх треба повторно затягнути через 2 тижні після монтажу, а потім кожні 3 місяці. Це необхідно для того, щоб забезпечити надійне використання продукту протягом терміну його служби.
- RO: IMPORTANT**
Este important ca șuruburile de orice tip, cu ajutorul cărora au fost montate produsele, să fie strânse din nou la 2 săptămâni după montare și, apoi, o dată la 3 luni, pentru a se asigura stabilitatea de-a lungul duratei de viață a produsului
- BG: ВАЖНО!**
Важно е всеки продукт, който е сглобен с помощта на винтове, да бъде затегнат 2 седмици след сглобяването, и веднъж на всеки 3 месеца, за да се гарантира стабилност през цялото време на използване на продукта.
- GR: ΣΗΜΑΝΤΙΚΟ!**
Για κάθε προϊόν που συναρμολογείται με βίδες είναι σημαντικό αυτές να ελασφίγγονται 2 εβδομάδες μετά τη συναρμολόγηση και μία φορά κάθε 3 μήνες, για τη διασφάλιση της σταθερότητας σε όλη τη διάρκεια ζωής του προϊόντος.
- PT: AVISO IMPORTANTE!**
É importante, em cada produto montado com parafusos, reapertar os mesmos 2 semanas após a montagem e uma vez a cada 3 meses para garantir a estabilidade do produto ao longo de toda a sua vida útil.
- RU: ВАЖНО!**
В любом изделии, собранном с использованием винтов любого типа, необходимо через 2 недели после сборки и в дальнейшем каждые 3 месяца подтягивать винты, чтобы обеспечить прочность изделия в течение срока эксплуатации.
- TR: ÖNEMLİ!**
Vida kullanılarak yapılan her türlü ürün montajı için montajdan 2 hafta sonra vidaların yeniden sıkıştırılması ve kullanım süresi boyunca ürün istikrarının sağlanması için de her 3 ayda bir vidaların sıkıştırılması önem arz eder.
- CN: 重要提示!**
使用任何类型的螺钉组装的产品，必须在组装 2 周后重新拧紧，并且每 3 个月重新拧紧一次，以确保产品在整个使用期内结实稳固。



- GB:** **GENERAL INSTRUCTION FOR FURNITURE MADE OF WOOD OR WOOD COMPOSITES SUCH AS MELAMINE, LAMINATE OR VENEER SURFACES!**
Wipe clean with a damp cloth. Use only water or a gentle detergent.
Wipe dry with a clean cloth.
- DK:** **GENEREL VEJLEDNING TIL MØBLER FREMSTILLET AF TRÆ ELLER TRÆKOMPOSITMATERIALER SOM MELAMIN, LAMINAT ELLER FINER!**
Rengøres med en fugtig klud. Anvend kun vand eller et mildt vaskemiddel.
Tørres af med en ren klud.
- DE:** **ALLGEMEINE HINWEISE FÜR MÖBEL AUS HOLZ ODER HOLZ-VERBUNDWERKSTOFFEN WIE MELAMIN-, LAMINAT- ODER FURNIEROBERFLÄCHEN!**
Mit einem feuchten Tuch abwischen. Nur Wasser oder ein mildes Reinigungsmittel verwenden.
Mit einem sauberen Tuch trocken reiben.
- NO:** **GENERELLE INSTRUKSJONER FOR MØBLER LAGET AV TRE ELLER TREKOMPOSITT SOM MELAMIN, LAMINAT ELLER FINER!**
Tørk av med en fuktig klut. Bruk bare vann eller et mildt vaskemiddel.
Tørk av med en ren klut.
- SE:** **ALLMÄNNA INSTRUKTIONER GÄLLANDE MÖBLER AV TRÄ ELLER TRÄKOMPOSIT SÅSOM MELAMIN, LAMINAT ELLER FANER!**
Torka rent med en fuktig trasa. Använd endast vatten eller ett mildt rengöringsmedel. Torka torrt med en ren trasa.
- FI:** **YLEISIÄ OHJEITA PUUSTA JA PUUKOMPOSIITTIMATERIAALEISTA KUTEN MELAMIINISTA, LAMINAATISTA TAI VANERISTA VALMISTETUILLE KALUSTEILLE!**
Pyyhi puhtaaksi kostealla liinalla. Käytä vain vettä tai mietoä pesuainetta.
Kuivaa puhtaalla liinalla.
- PL:** **OGÓLNE INSTRUKCJE DOTYCZĄCE MEBLI Z DREWNA ORAZ MATERIAŁÓW DREWNOPOCHODNYCH: MELAMINA, LAMINAT, OKLEINA**
Do czyszczenia należy używać wilgotnej ściereczki. Używać wyłącznie wody lub delikatnego detergentu.
Wycierać do sucha ściereczką.
- CZ:** **OBECNÉ POKYNY TÝKAJÍCÍ SE NÁBYTKU VYROBENÉHO ZE DŘEVA NEBO Z KOMPOZITŮ DŘEVA, NAPŘ. S POVRCHEM Z MELAMINU, LAMINÁTU NEBO DÝHY!**
Čistěte otřením navlhčeným hadříkem. Používejte pouze vodu nebo jemný čistící prostředek.
Vytřete dosucha čistým hadříkem.
- HU:** **ÁLTALÁNOS ÚTMUTATÁS A FÁBÓL KÉSZÜLT VAGY ÖSSZETETT FAANYAGOT, PÉLDÁUL MELAMIN-, LAMINÁLT VAGY FURNÉRFELÜLETET TARTALMAZÓ BÚTOROKHOZ**
Törölje tisztára nedves ruhával. Csak vizet vagy kímélő tisztítószert használjon.
Törölje szárazra tiszta ruhával.
- NL:** **ALGEMENE INSTRUCTIES VOOR MEUBELS VERVAARDIGD UIT HOUT OF HOUTCOMPOSITET ALS MELAMINE, LAMINAAT OF FINEEROPPERVLAKKEN!**
Reinig met een vochtige doek. Gebruik alleen water of wasmiddel.
Droogwrijven met een schone doek.
- SK:** **VŠEOBECNÉ POKYNY PRE NÁBYTOK VYROBENÝ Z DREVA ALEBO KOMPOZITNÝCH MATERIÁLOV, NAPRIKLAD MELAMÍNU, LAMINÁTU ALEBO PREGLEJKOVÝCH POVRCHOV!**
Utrite dočista navlhčenou utierkou. Používajte iba vodu alebo jemný čistiaci prostriedok.
Utrite dosucha čistou utierkou.
- FR:** **INSTRUCTIONS GÉNÉRALES POUR LE MOBILIER CONSTITUÉ DE BOIS OU DE COMPOSITES DE BOIS (COMME LES SURFACES EN MELAMINÉ, STRATIFIÉ OU PLACAGE)**
Nettoyer à l'aide d'un chiffon humide. Utiliser uniquement de l'eau ou un détergent doux.
Essuyer à l'aide d'un chiffon propre.
- SI:** **SPLOŠNA NAVODILA ZA VZDRŽEVANJE POHIŠTVA IZ LESA ALI LESENIH KOMPOZITOV, KOT SO MELANIN, LAMINAT ALI FURNIR!**
Obrišite z vlažno krpo. Uporablajte le vodo ali blag detergent.
Posušite s čisto krpo.
- HR:** **OPĆE UPUTE ZA NAMJEŠTAJ IZRAĐEN OD DRVA ILI DRVNIH KOMPOZITA, KAO ŠTO SU POVRŠINE OD MELAMINA, LAMINATA ILI FURNIRA!**
Očistite vlažnom krpom. Upotrijebite samo vodu ili blagi deterđent.
Posušite čistom krpom.
- IT:** **ISTRUZIONI GENERALI PER MOBILI IN LEGNO O COMPOSITI DI LEGNO COME LE SUPERFICI IN MELAMINA. LAMINATO O IMPIALLACCIATURA!**
Pulire con un panno umido. Utilizzare solo acqua o un detergente delicato.
Asciugare con un panno pulito.
- ES:** **INSTRUCCIONES GENERALES ACERCA DE LOS MUEBLES CON SUPERFICIES DE MADERA, COMPUESTOS DE MADERA COMO MELANINA, LAMINADAS O CONTRACHAPADAS**
Limpiar con un paño húmedo. Usar solo agua o un detergente suave.
Secar con un paño limpio.
- BA:** **OPŠTA UPUTSTVA ZA NAMJEŠTAJ OD DRVETA ILI DRVENIH KOMPOZITA, NA PRIMJER ZA POVRŠINE OD MELAMINA, LAMINATA ILI FURNIRA.**
Obrisati vlažnom krpom. Koristiti samo vodu ili blagi deterđent.
Posušiti suhom krpom.
- RS:** **OPŠTA UPUTSTVA ZA NAMEŠTAJ NAPRAVLJEN OD DRVETA ILI DRVENOG KOMPOZITA KAO ŠTO SU MELAMIN, LAMINAT ILI FURNIR POVRŠINE!**
Obrišite vlažnom krpom. Koristite samo vodu ili blagi deterđent.
Prebrišite suvom, čistom krpom.
- UA:** **ЗАГАЛЬНА ІНСТРУКЦІЯ ДЛЯ МЕБЛІВ, ВИГОТОВЛЕНИХ З ДЕРЕВА ЧИ ДЕРЕВ'ЯНИХ КОМПОНЕНТІВ, НАПРИКЛАД, МЕЛАМІНУ, ЛАМІНАТА АБО ШПОНУ.**
Протірайте за допомогою вологої ганчірки. Використовуйте воду або слабкий розчин миючого засобу.
Витирайте чистою ганчіркою.
- RO:** **INSTRUCȚIUNI GENERALE PENTRU PIESELE DE MOBILIER REALIZATE DIN LEMN SAU DIN COMPUȘI DIN LEMN PRECUM SUPRAFEȚELE MELAMINATE, LAMINATE SAU FURNIRUITE!**
Curățați prin ștergere cu o lavetă umeză. Utilizați numai apă sau un detergent delicat.
Uscați prin ștergere cu o lavetă curată.
- BG:** **ОБЩА ИНСТРУКЦИЯ ЗА МЕБЕЛИ, ИЗРАБОТЕНИ ОТ ДЪРВО ИЛИ ДЪРВЕНИ КОМПОЗИТНИ МАТЕРИАЛИ, КАТО МЕЛАМИН, ЛАМИНАТ ИЛИ ФУРНИРНИ ПОВЪРХНОСТИ!**
Избършете с влажна кърпа. Използвайте само вода или лек почистващ препарат.
Подсушете с чиста кърпа.
- GR:** **ΓΕΝΙΚΕΣ ΟΔΗΓΙΕΣ ΓΙΑ ΕΠΙΠΛΑ ΑΠΟ ΞΥΛΟ Ή ΣΥΝΘΕΤΙΚΟ ΞΥΛΟ ΟΠΩΣ ΜΕΛΑΜΙΝΗ, ΛΑΜΙΝΕΪΤ Ή ΛΟΥΣΤΡΑΡΙΣΜΕΝΕΣ ΕΠΙΦΑΝΕΙΕΣ!**
Σκουπίζετε με ένα υγρό πανί. Χρησιμοποιείτε μόνο νερό ή ένα ήπιο απορρυπαντικό.
Στεγνώνετε με ένα καθαρό πανί.

- PT:** **INFORMAÇÕES GERAIS PARA MÓVEIS DE MADEIRA OU MATERIAIS COMPOSITOS DE MADEIRA, COMO SUPERFÍCIES DE MELAMINA, LAMINADO OU FOLHEADO**
*Limpar com um pano úmido. Usar apenas água ou detergente neutro.
Secar com um pano limpo.*
- RU:** **ОБЩИЕ УКАЗАНИЯ ОТНОСИТЕЛЬНО МЕБЕЛИ, ИЗГОТОВЛЕННОЙ ИЗ ДЕРЕВА ИЛИ ДРЕВЕСНЫХ КОМПОЗИЦИОННЫХ МАТЕРИАЛОВ, ТАКИХ КАК МЕЛАМИН, ЛАМИНАТ ИЛИ ШПОН!**
*Очистите изделие чистой влажной тканью. Используйте мягкодействующее моющее средство.
Вытрите досуха чистой тряпкой.*
- TR:** **AHŞAP VEYA MELAMİN, LAMİNAT YA DA AHŞAP KAPLAMA GİBİ AHŞAP TÜREVİ YÜZEYLERDEN YAPILAN MOBİLYALARA YÖNELİK GENEL YÖNERGE!**
*Nemli bir bezle silerek temizleyin. Yalnızca su veya yumuşak bir deterjan kullanın.
Temiz bir bezle silerek kurulayın.*
- CN:** **针对实木及实木复合类（三聚氰胺面、层板、胶合板）家具的一般说明**
*请用湿布擦拭。只使用水或温和洗涤剂。
请用干净的布擦干。*



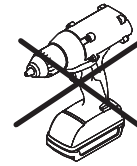
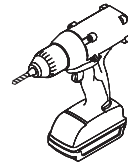
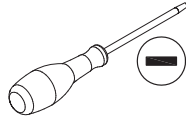
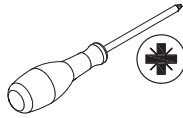
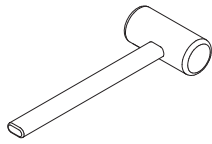

A x 12



Ø8x2mm

B x 11

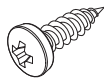

Ø3,5x12mm

C x 2

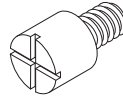

Ø10x18mm

D x 2

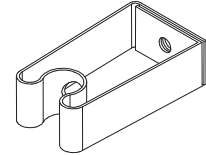

44x24x13mm

E x 2

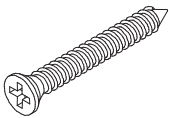

Ø4x30mm

F x 12

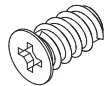

Ø6,3x11mm

G x 12

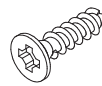

Ø3x12mm

H x 6



Ø15x10mm

J x 6

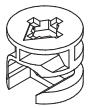

Ø15x13mm

K x 12

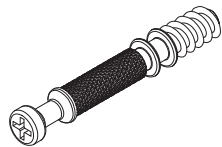

Ø7x45mm

L x 6

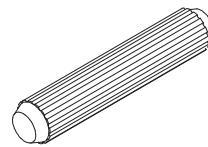

Ø8x45mm

M x 8

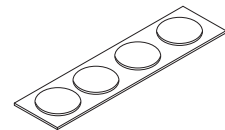

Ø20mm

N x 3

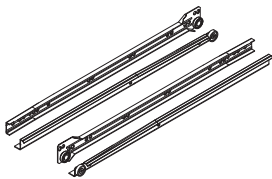

450mm

P x 3

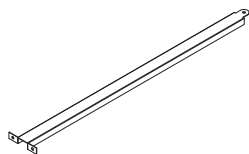

450x49x9,5mm

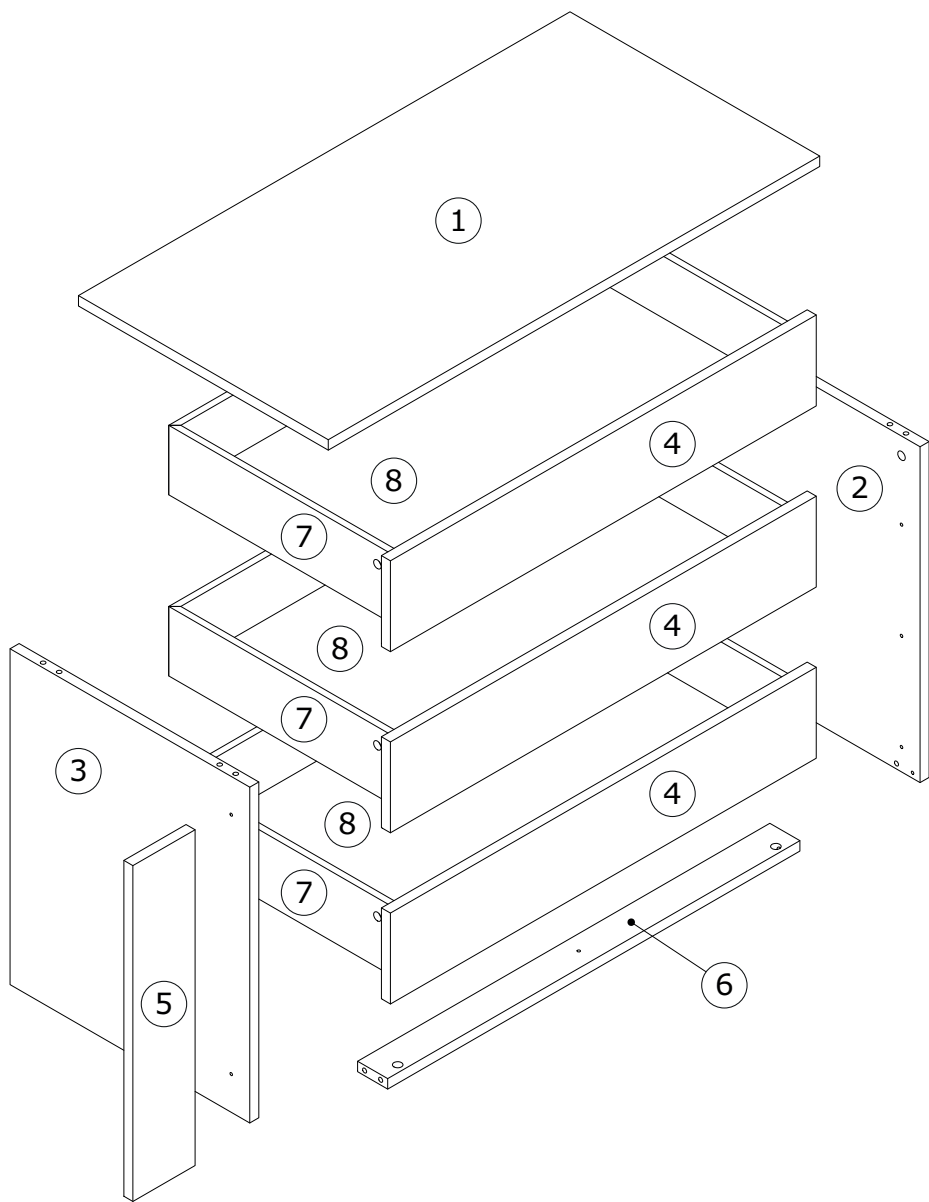

Box 1/1:

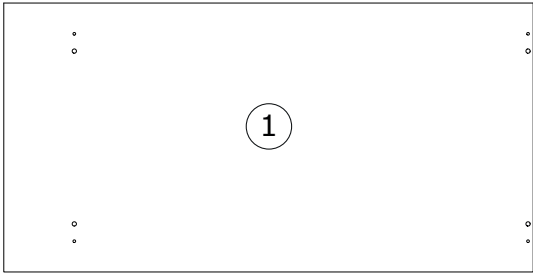

980x498x18mm

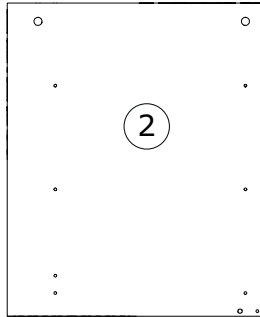

580x478x18mm

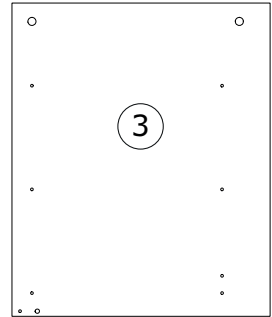

580x478x18mm

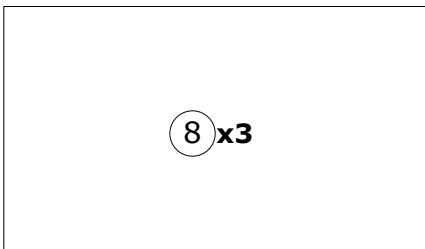

451x784x3mm

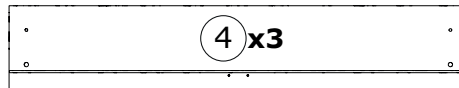

847x157x18mm

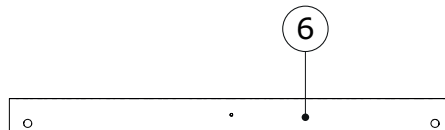

822x60x18mm



580x124x18mm

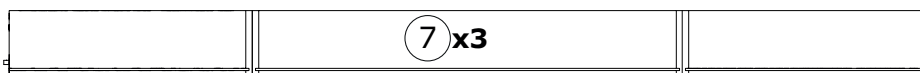

450x797x450mm H.120mm

1

K x 4



Ø7x45mm

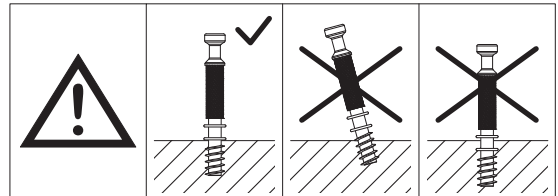
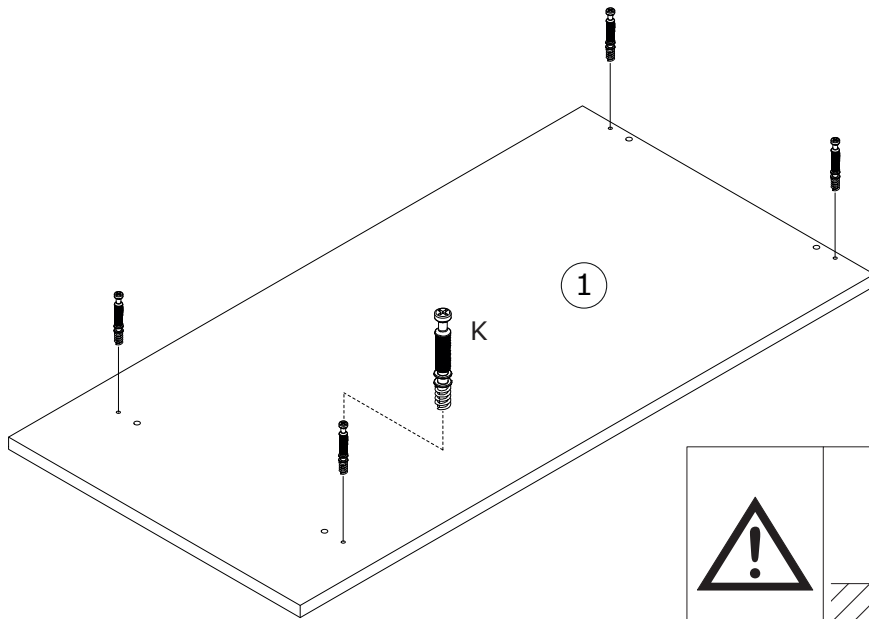
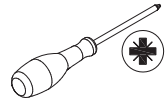

2

L x 4

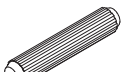

Ø8x45mm

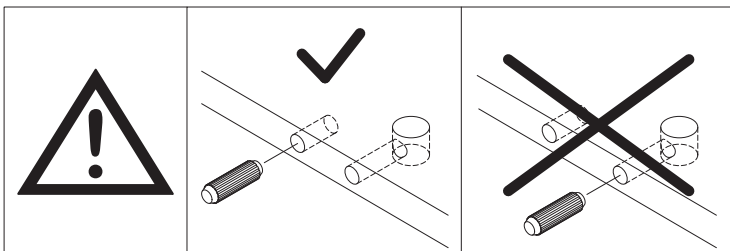
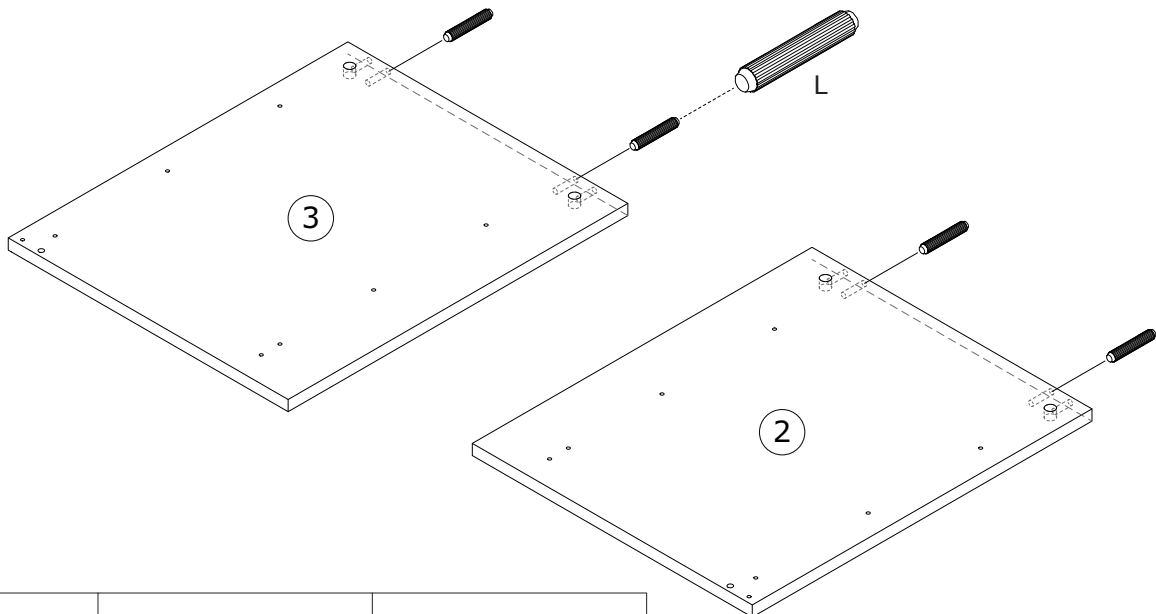
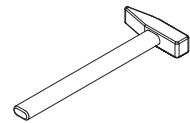

3

K x 2

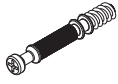

Ø7x45mm

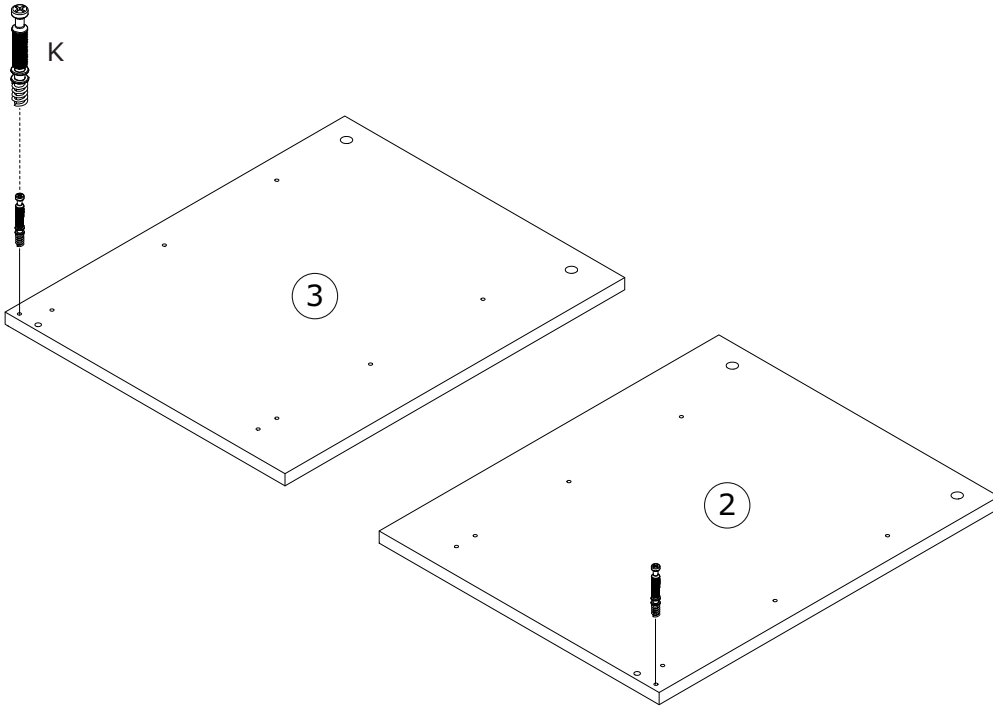
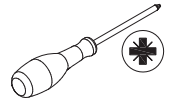

4

N x 3



450mm

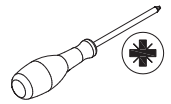

N=CL+DL+CR+DR

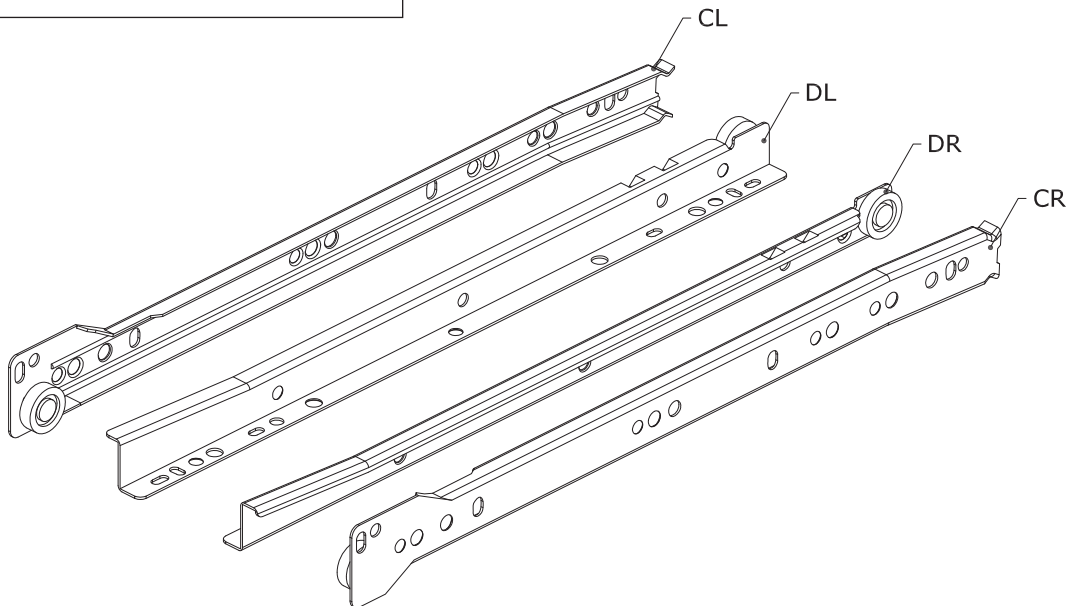

5

F x 6  Ø6,3x11mm	CL x 3  450mm	
---	--	---

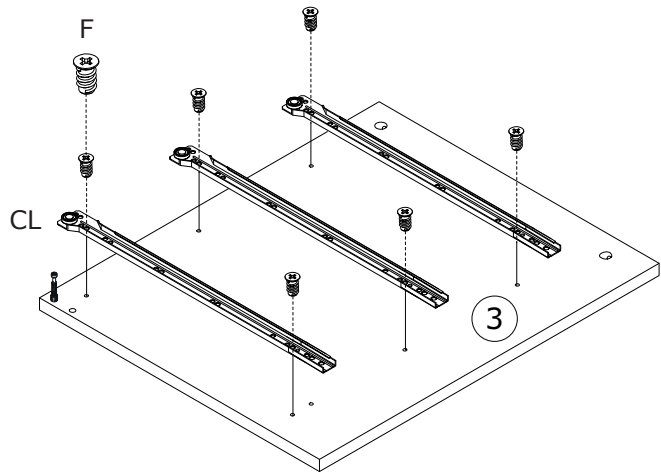
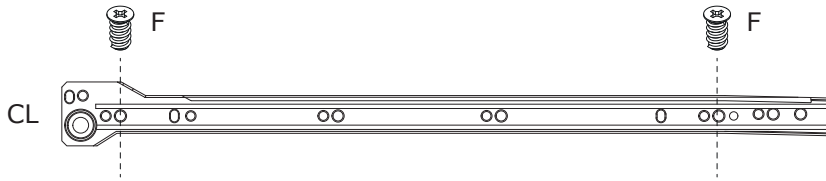

6

F x 6  Ø6,3x11mm	CR x 3  450mm	
---	--	---

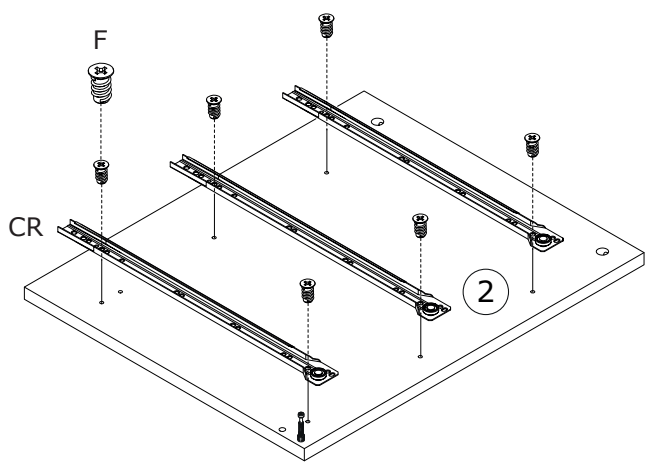
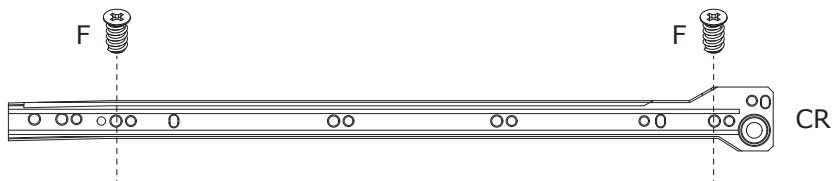

7

L x 2
Ø8x45mm

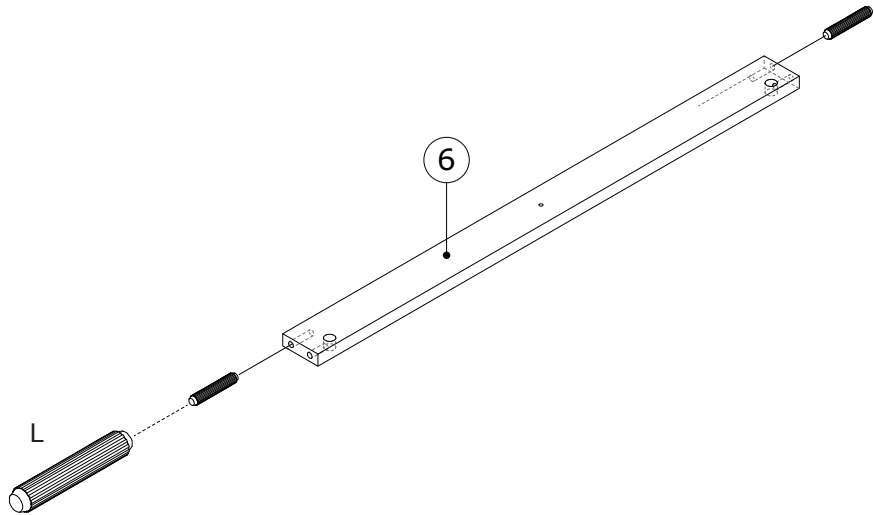
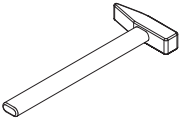

8

B x 2
Ø3,5x12mm

D x 2
44x24x13mm

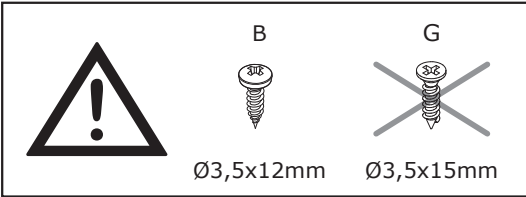
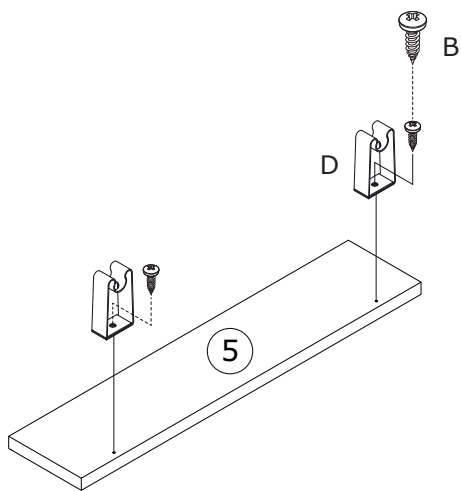
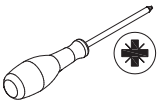

A

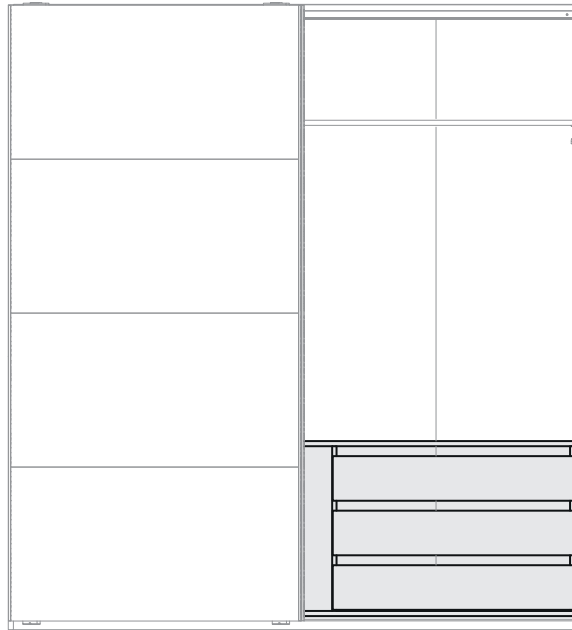
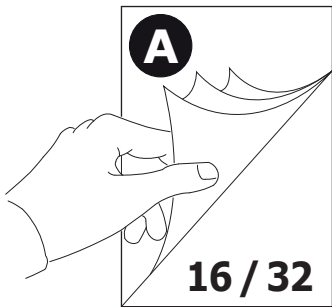

B

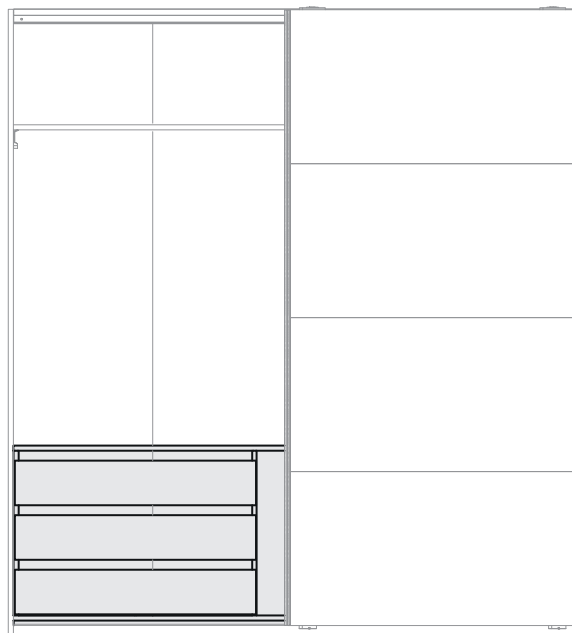
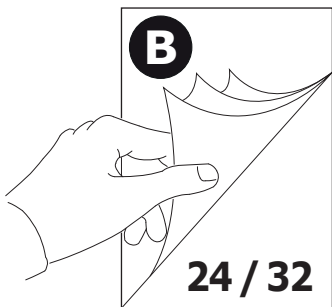



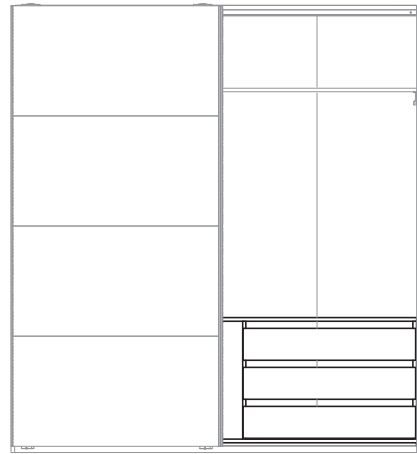
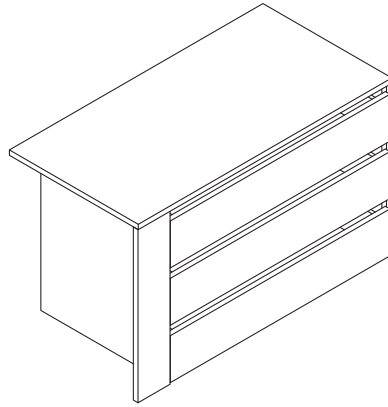

A

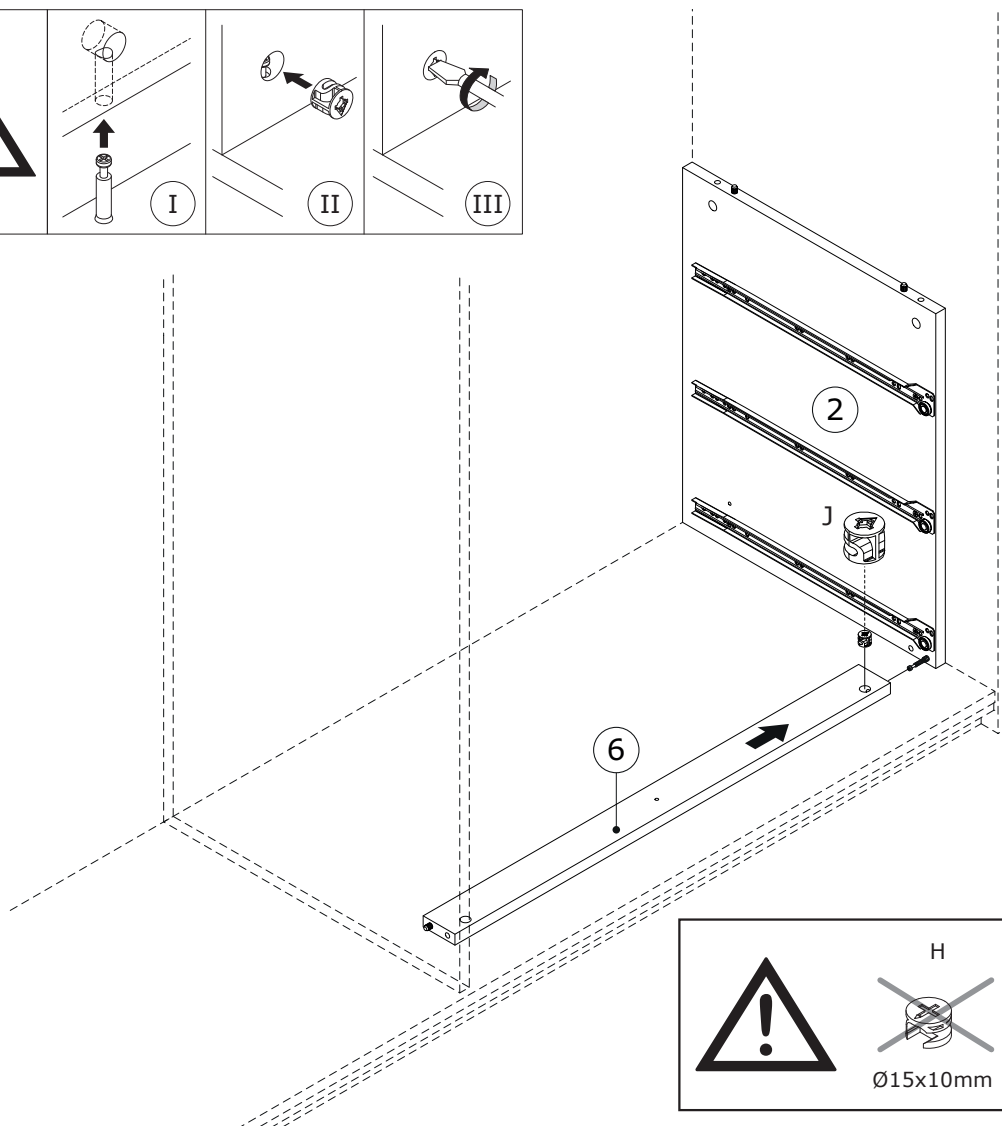
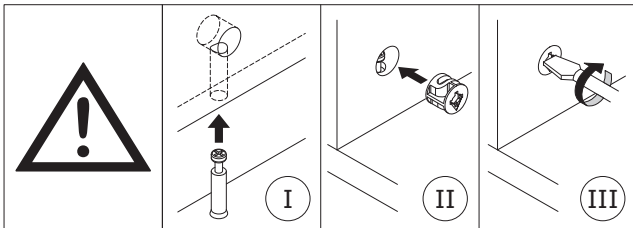

9

<p>J x 1</p>  <p>Ø15x13mm</p>	
--	---



	<p>H</p>  <p>Ø15x10mm</p>	<p>J</p>  <p>Ø15x13mm</p>
--	--	--

10

C x 2



Ø10x18mm

J x 1



Ø15x13mm

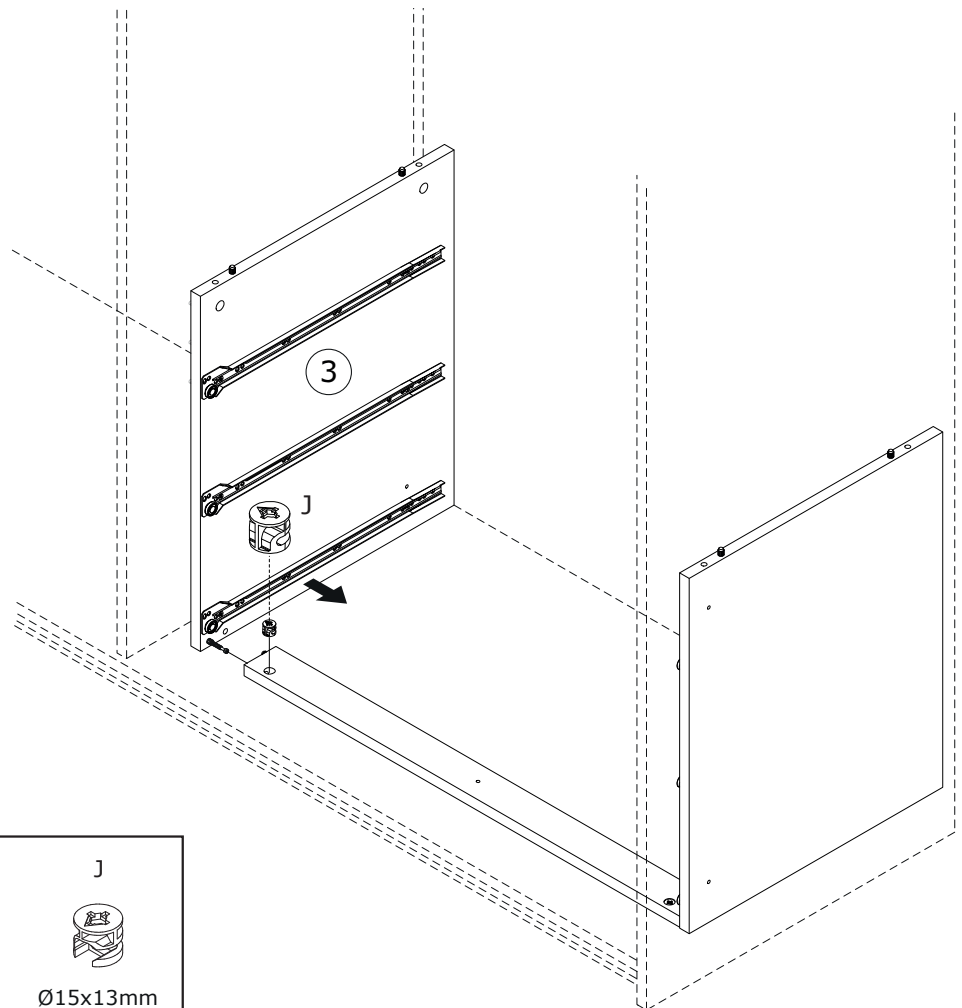
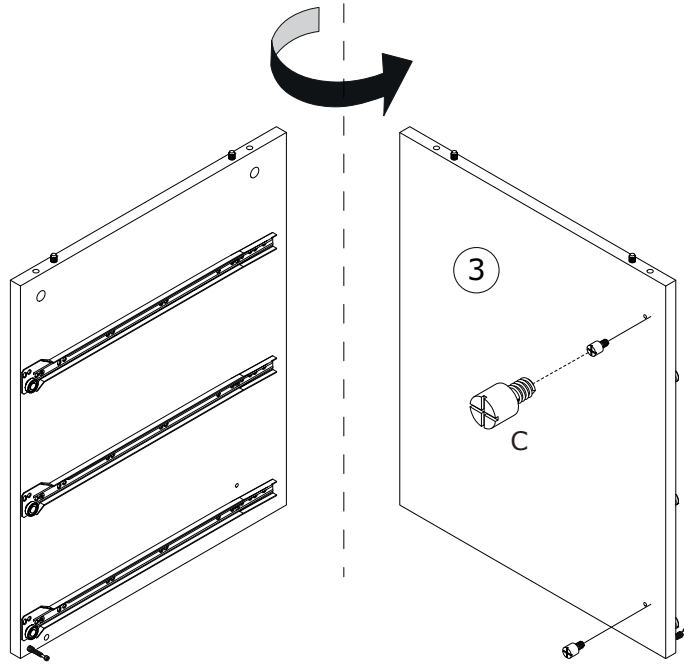

H



Ø15x10mm

J



Ø15x13mm

11

J x 4



Ø15x13mm

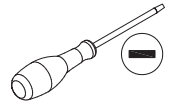

H



Ø15x10mm

J



Ø15x13mm

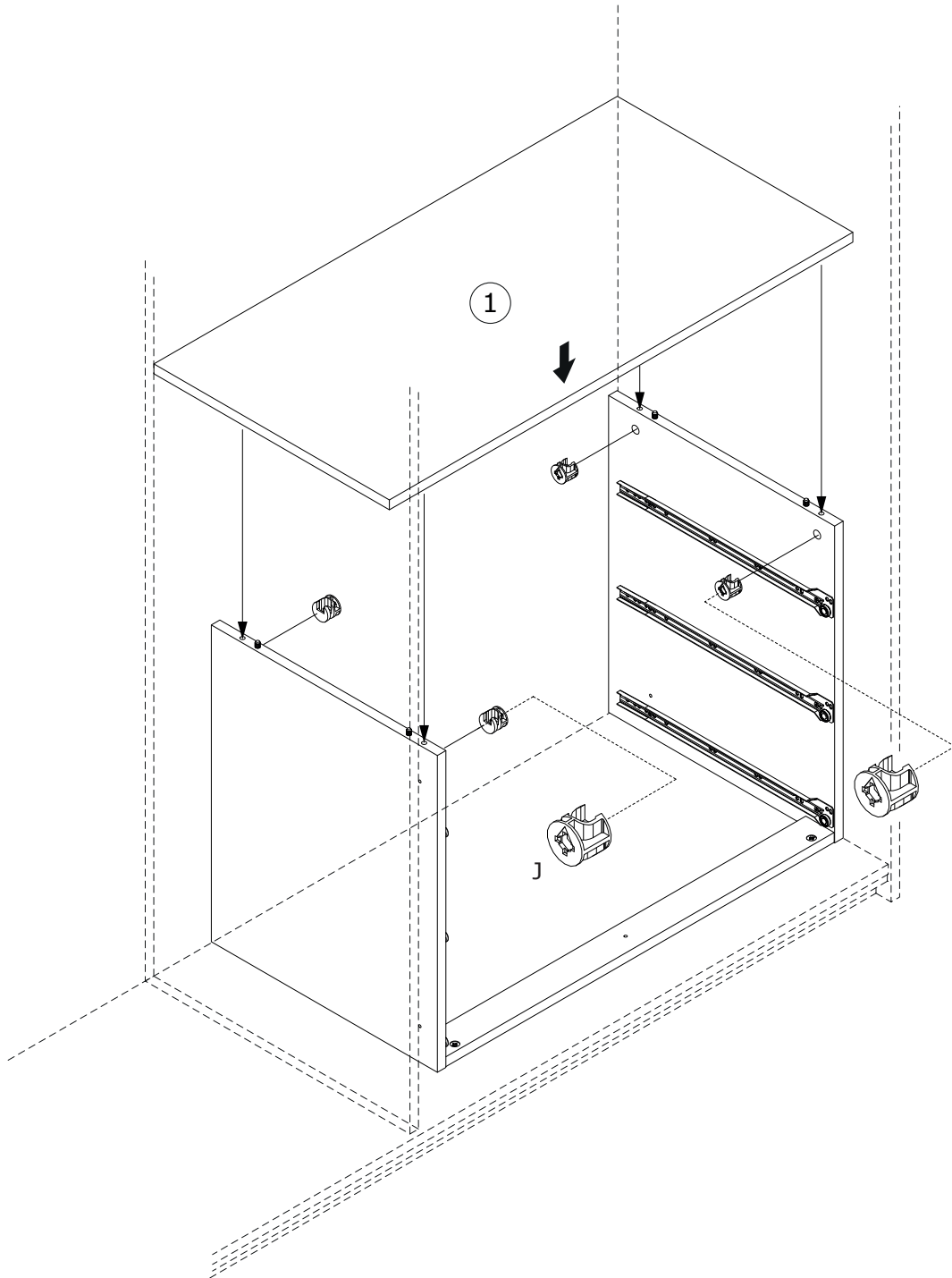

12

E x 2

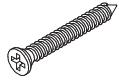

Ø4x30mm

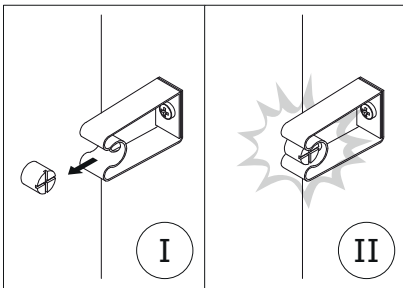
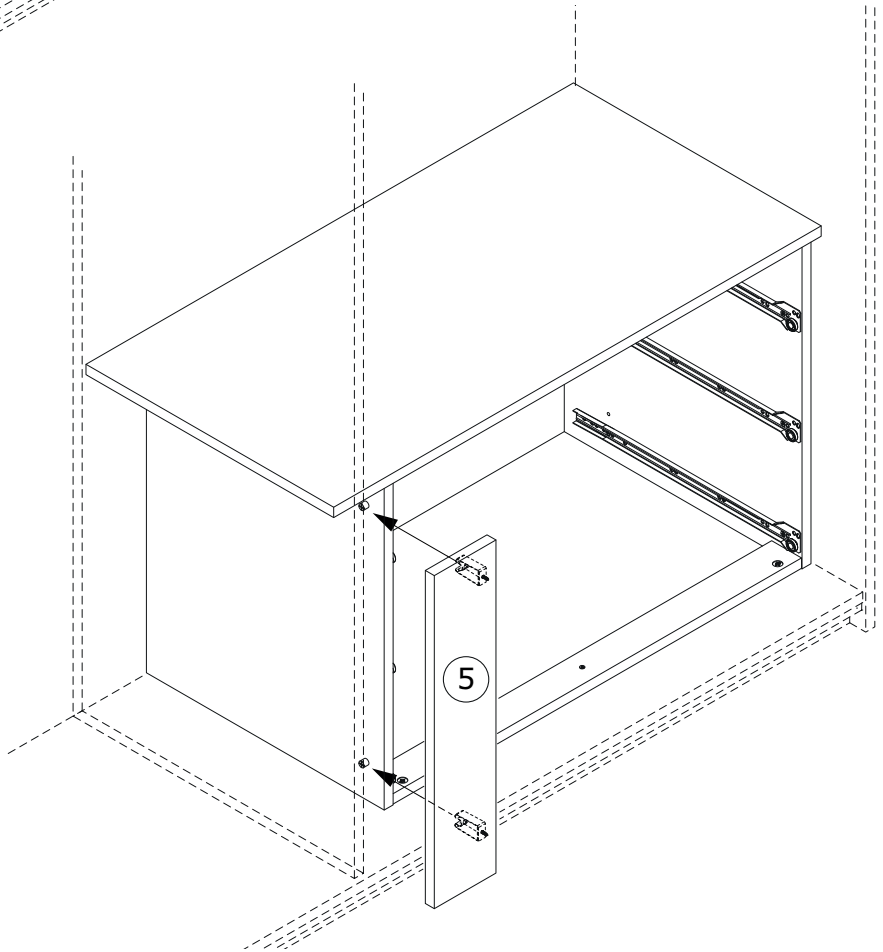
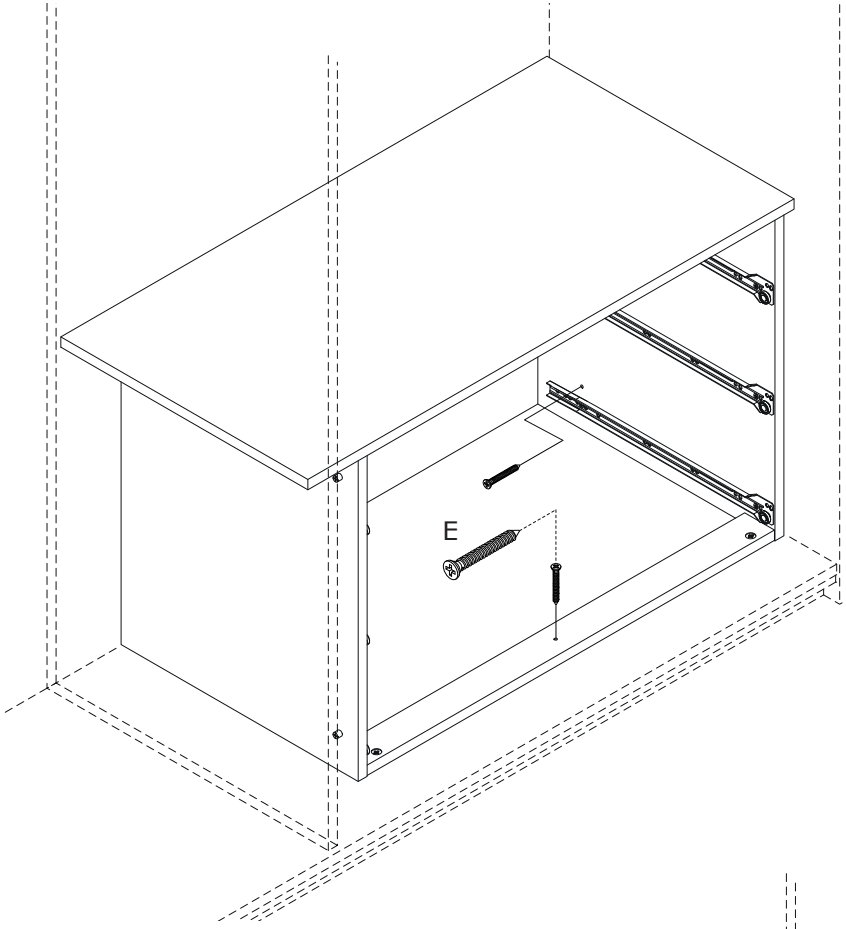
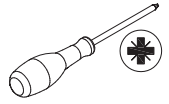

13

<p>K x 6</p>  <p>Ø7x45mm</p>	<p>A x 12</p>  <p>Ø8x2mm</p>	
---	---	---

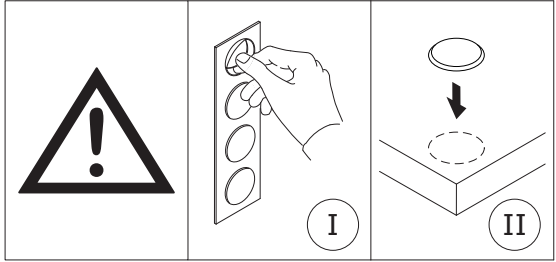
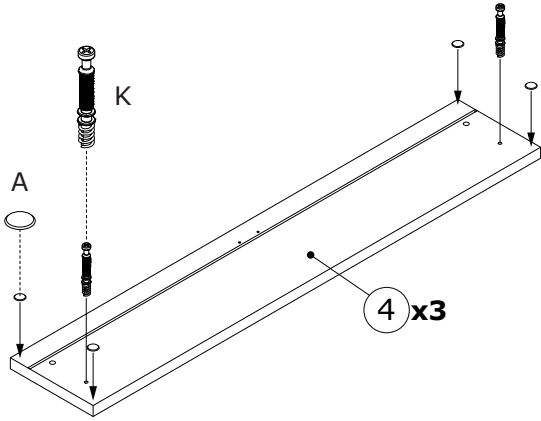

14

<p>H x 6</p>  <p>Ø15x10mm</p>	
---	--

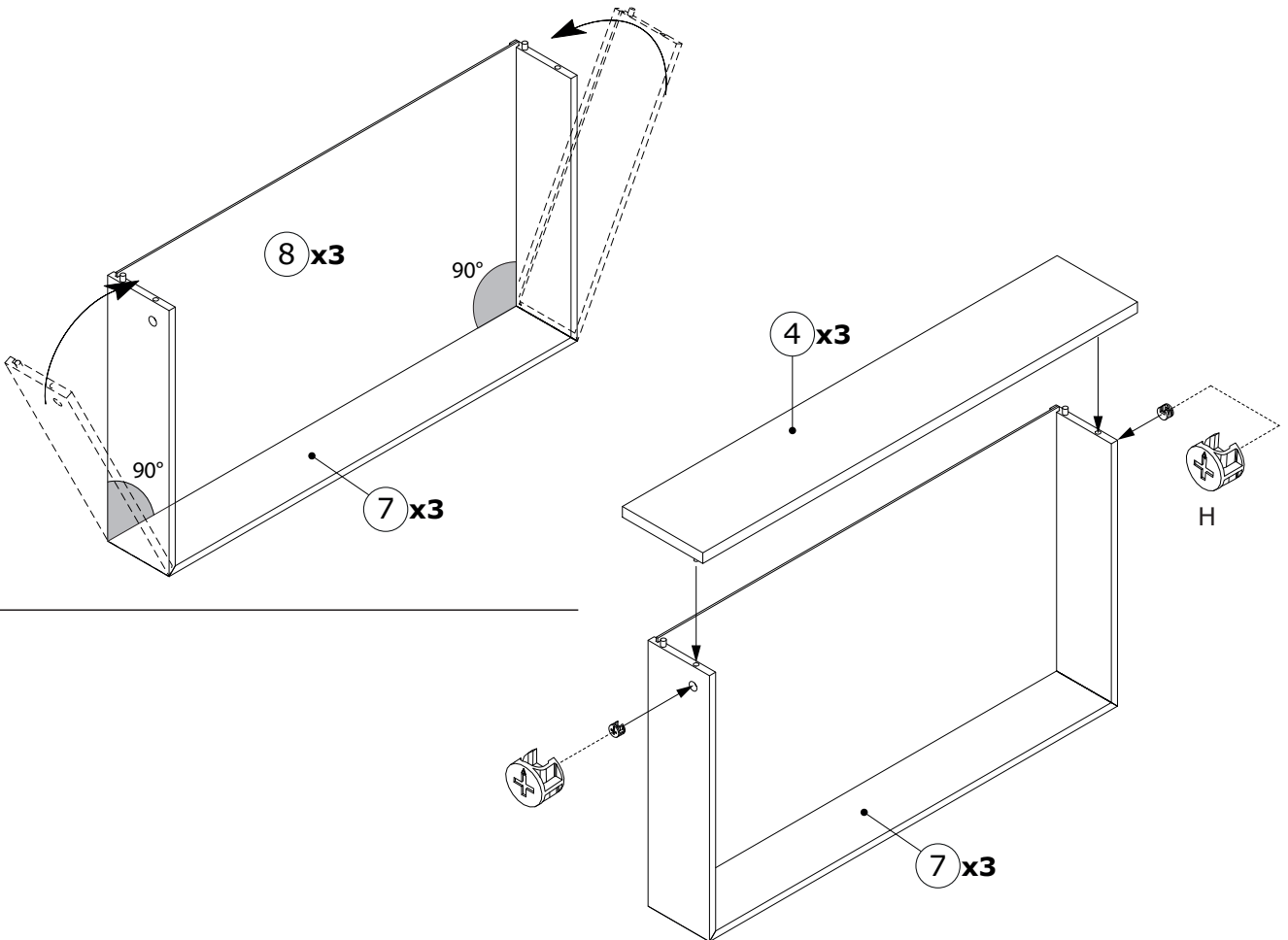

15

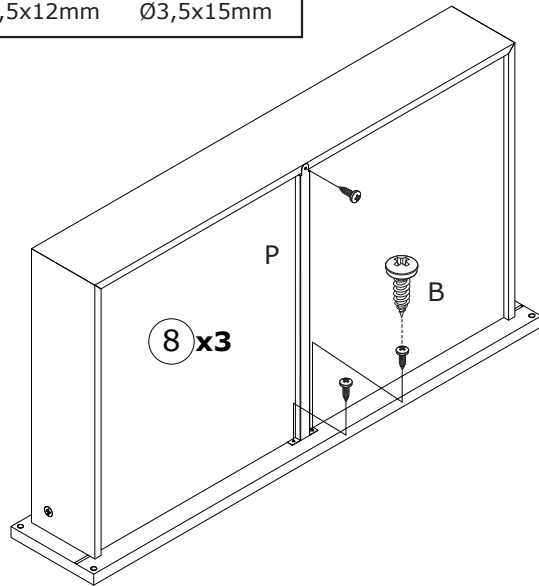
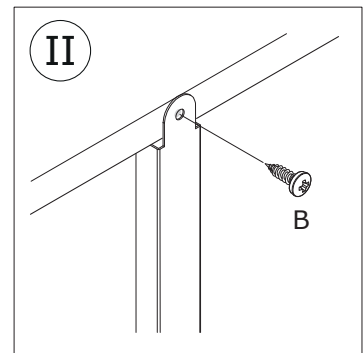
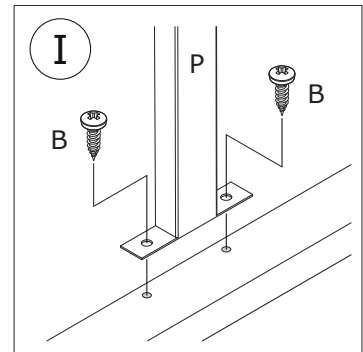
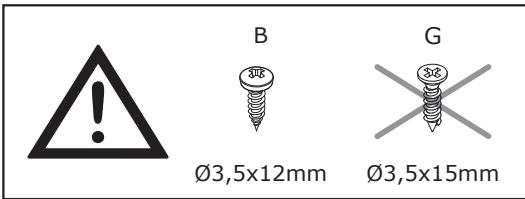
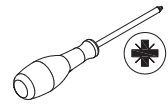
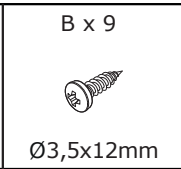
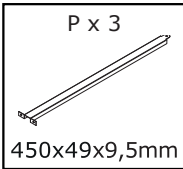

16

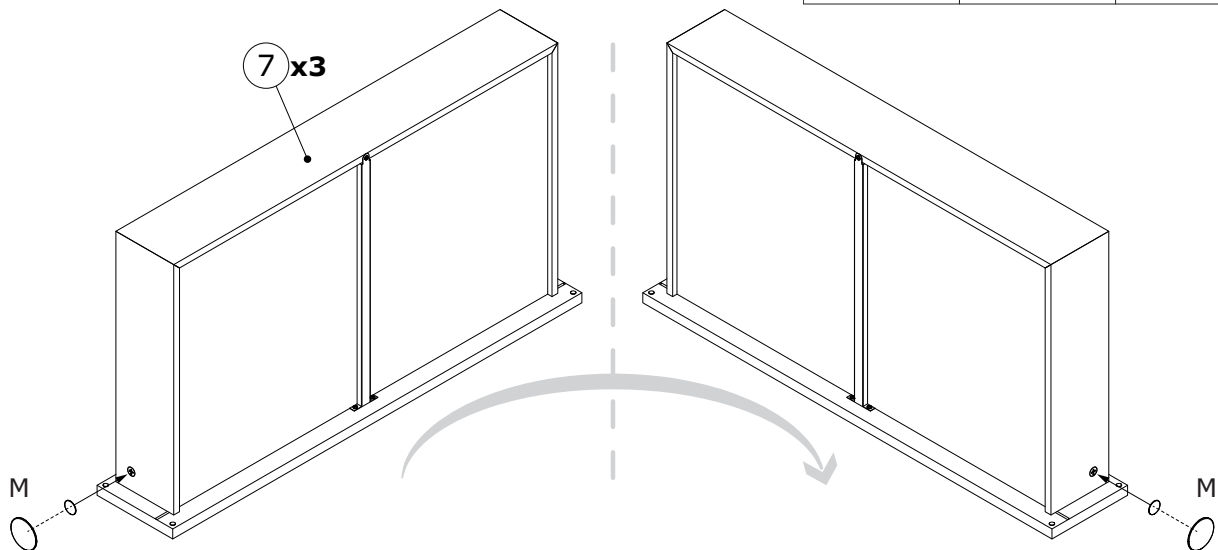
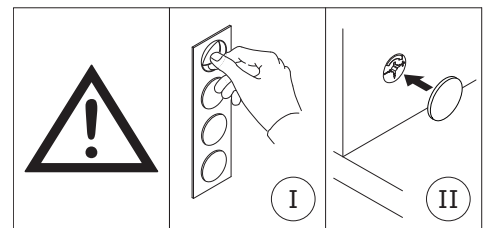
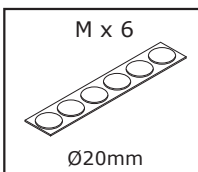

17

DL x 3  450mm	DR x 3  450mm	G x 12  Ø3x12mm	 
--	--	--	---

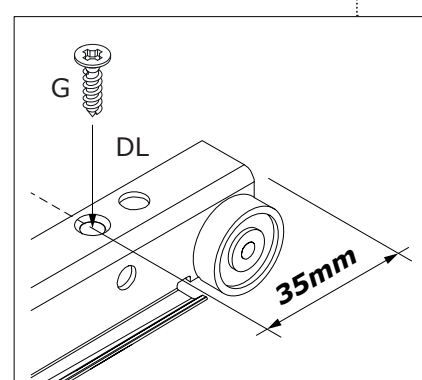
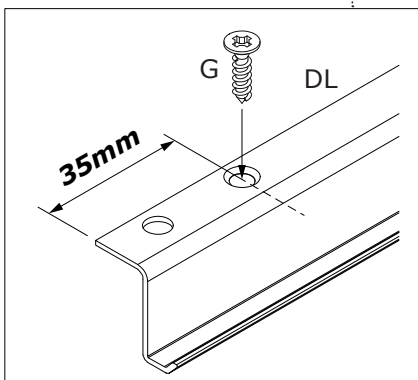
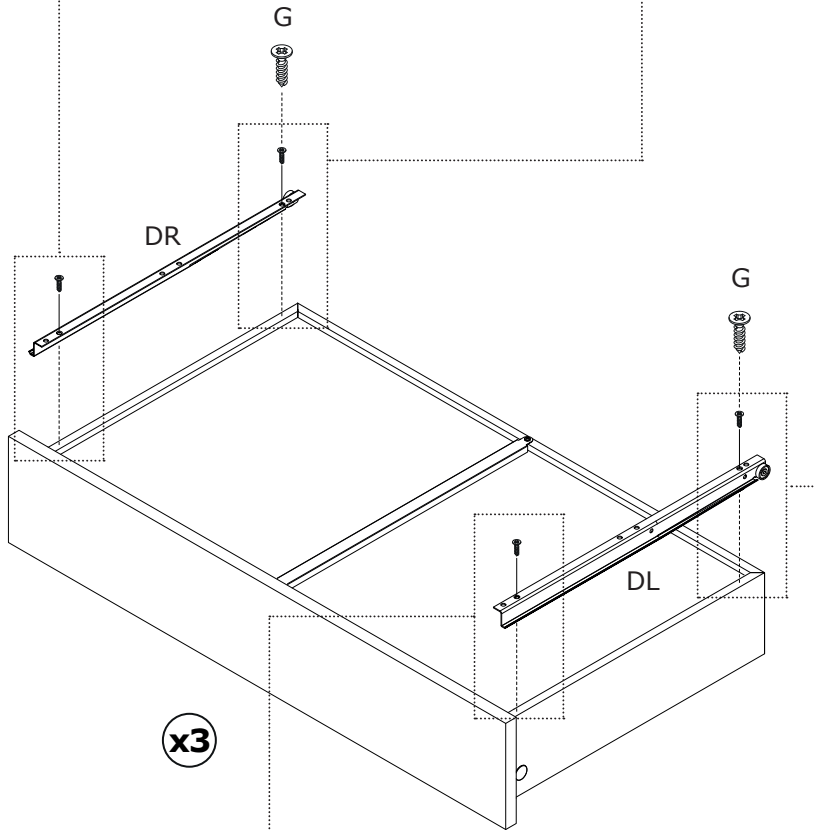
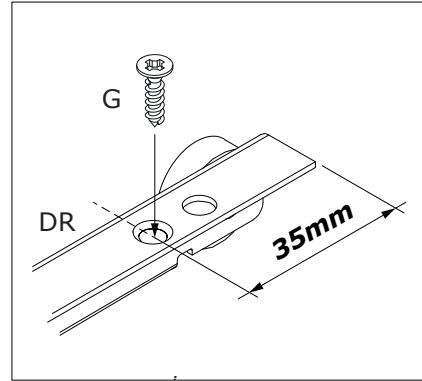
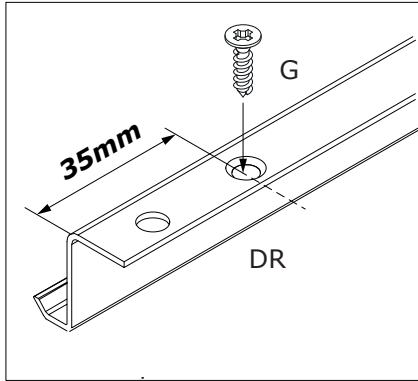

18

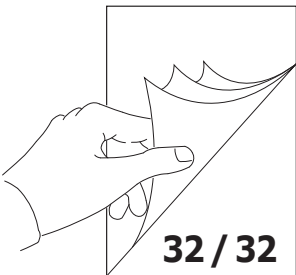
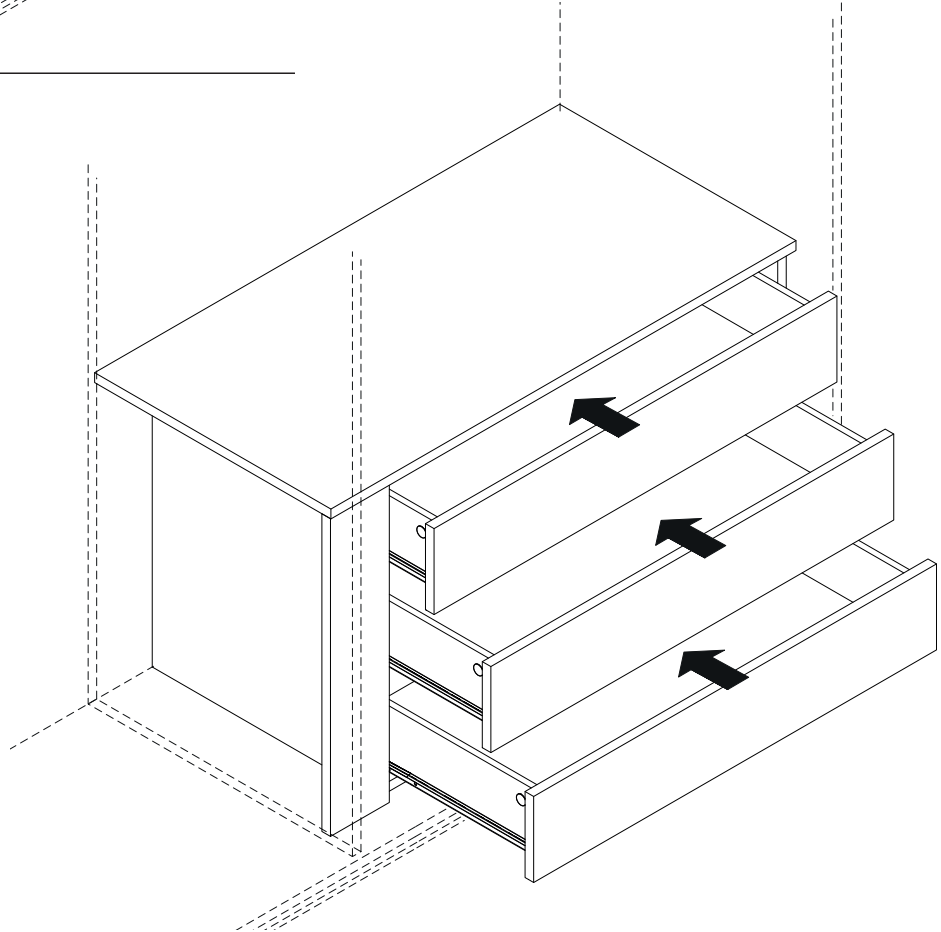
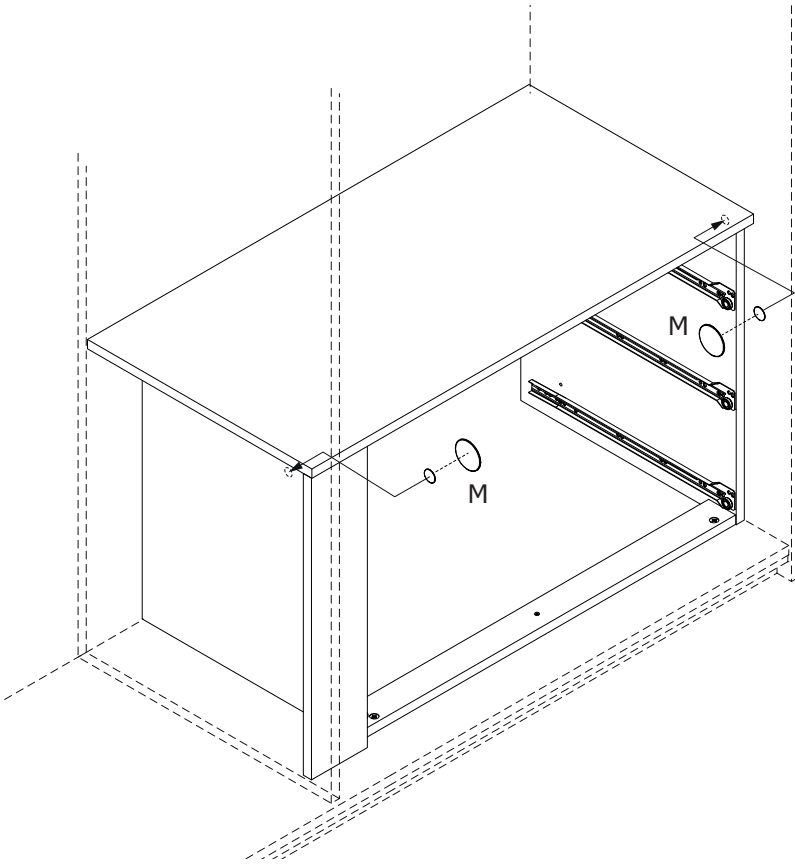
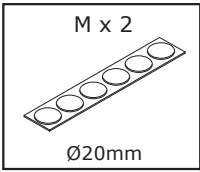



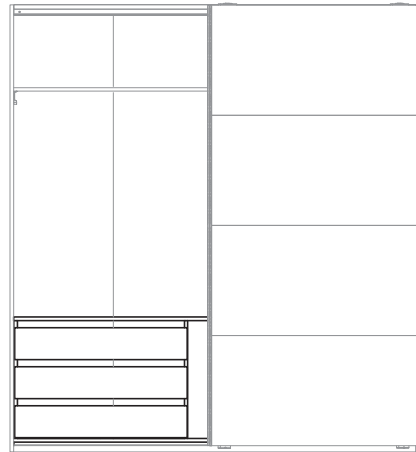
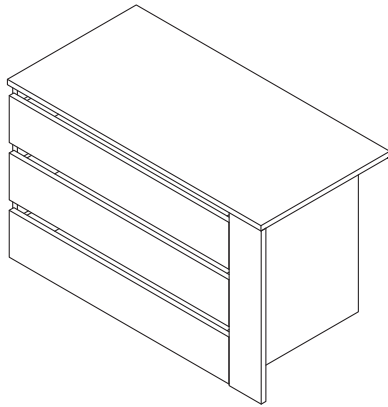

B

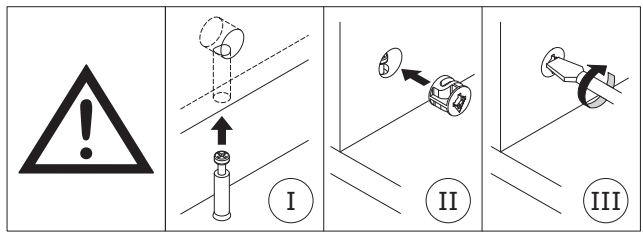
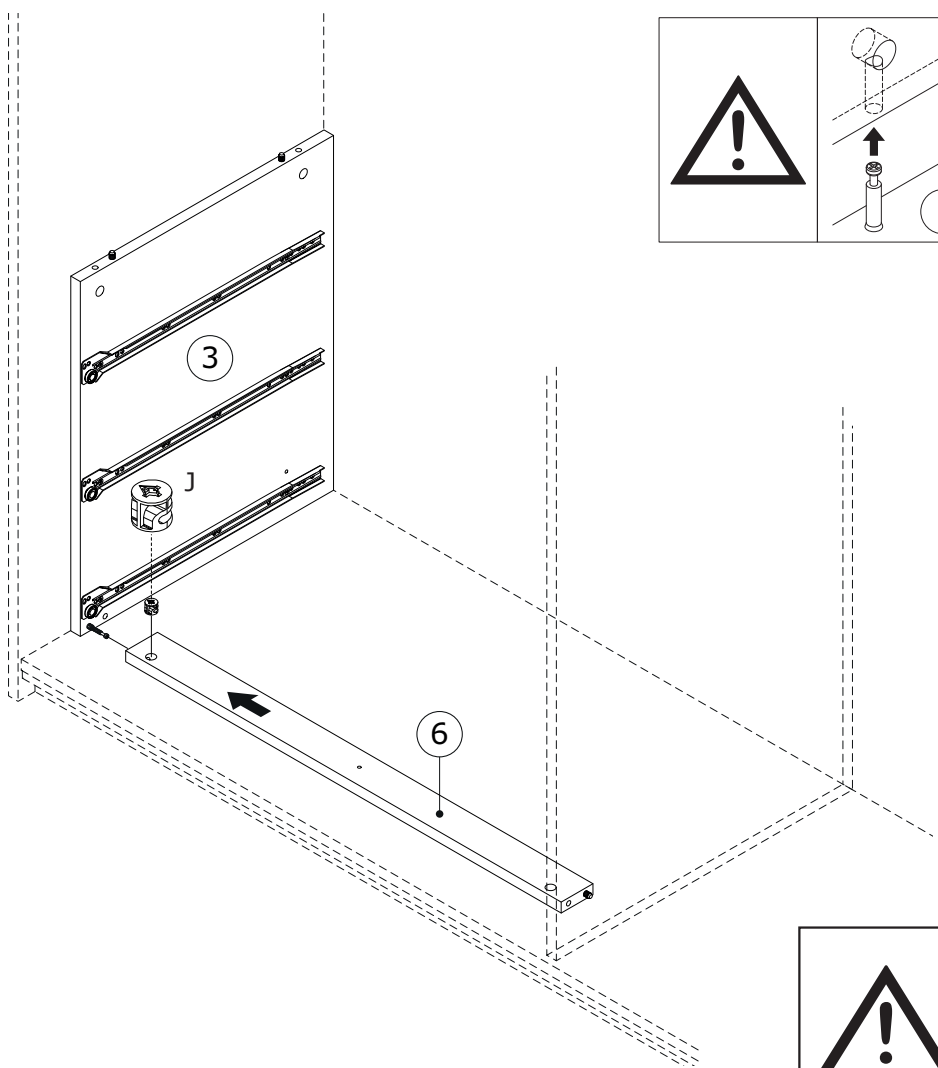

19

J x 1  Ø15x13mm	
--	---



	H  Ø15x10mm	J  Ø15x13mm
--	---	--

20

C x 2



Ø10x18mm

J x 1



Ø15x13mm

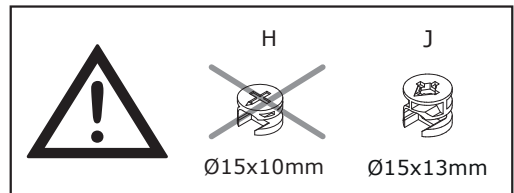
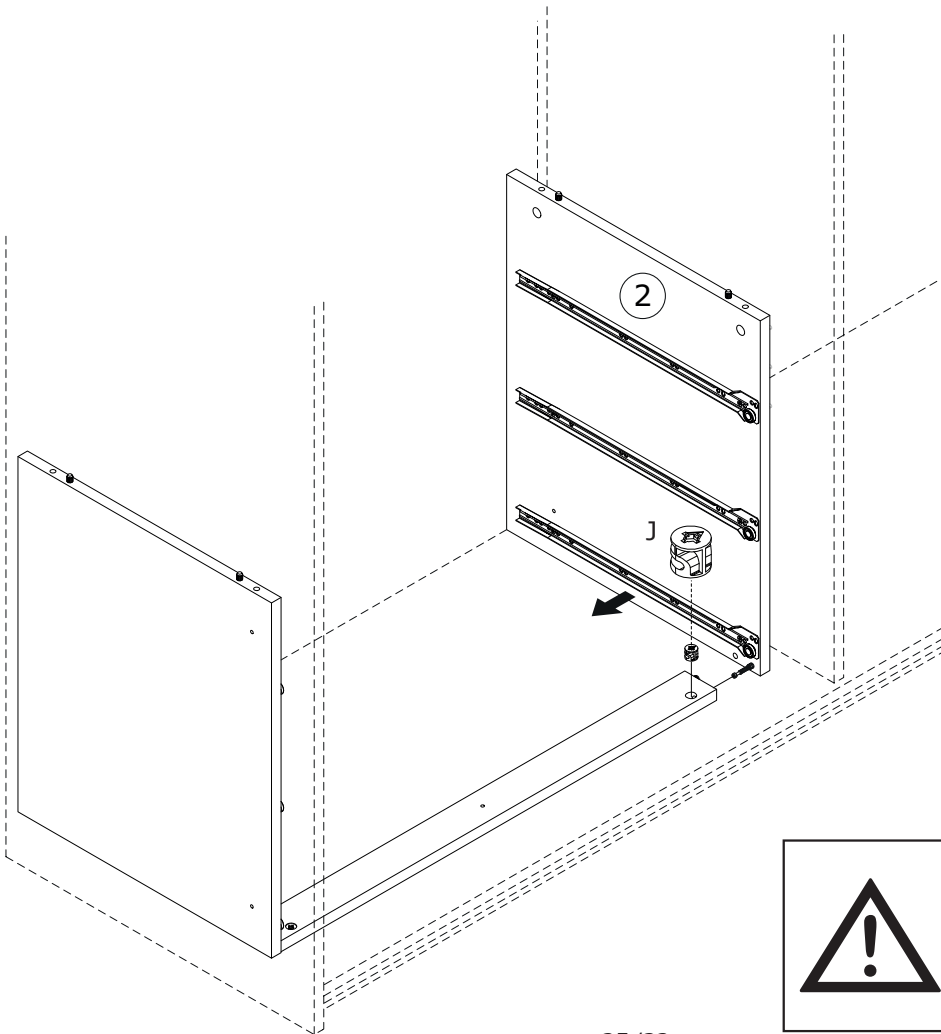
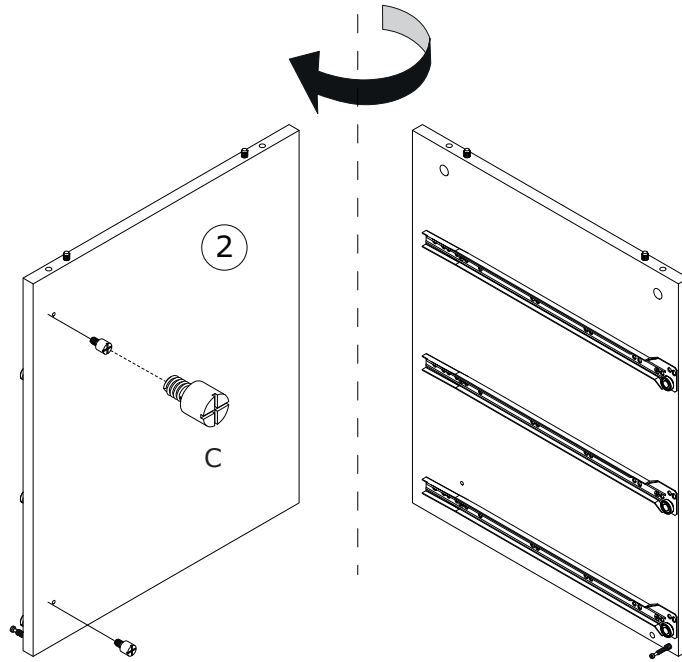

21

J x 4



Ø15x13mm

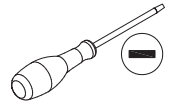

H



Ø15x10mm

J



Ø15x13mm

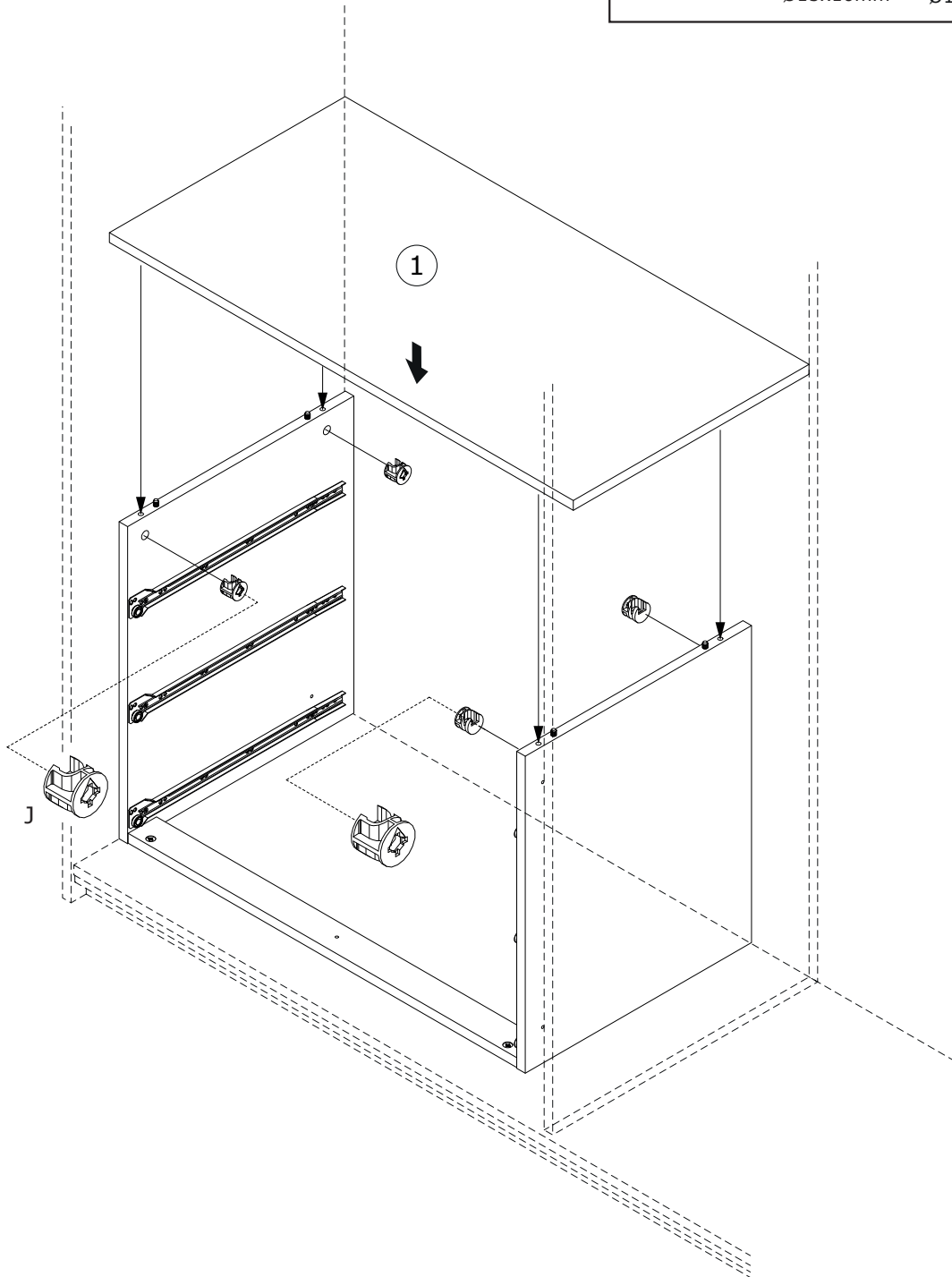

22

E x 2

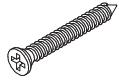

Ø4x30mm

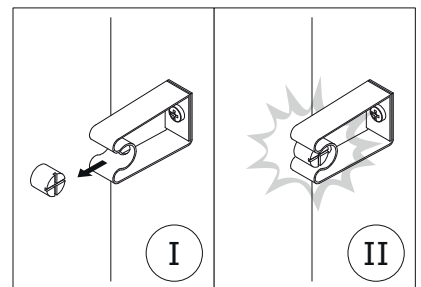
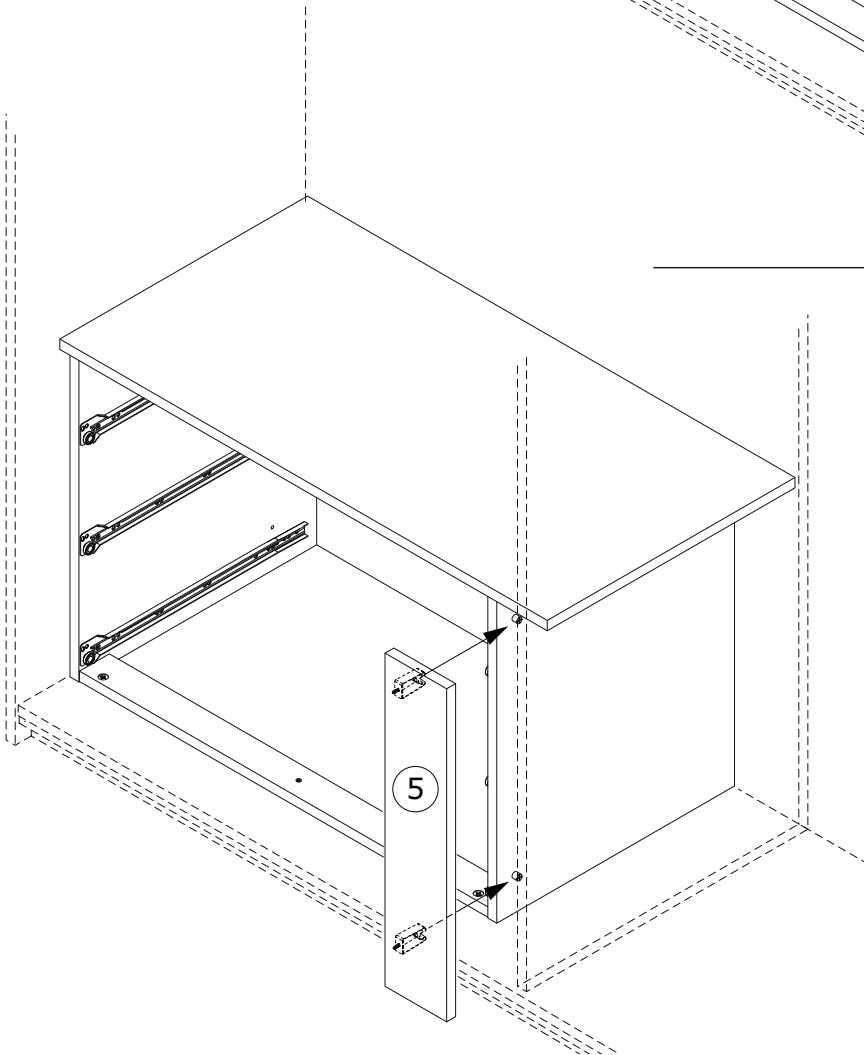
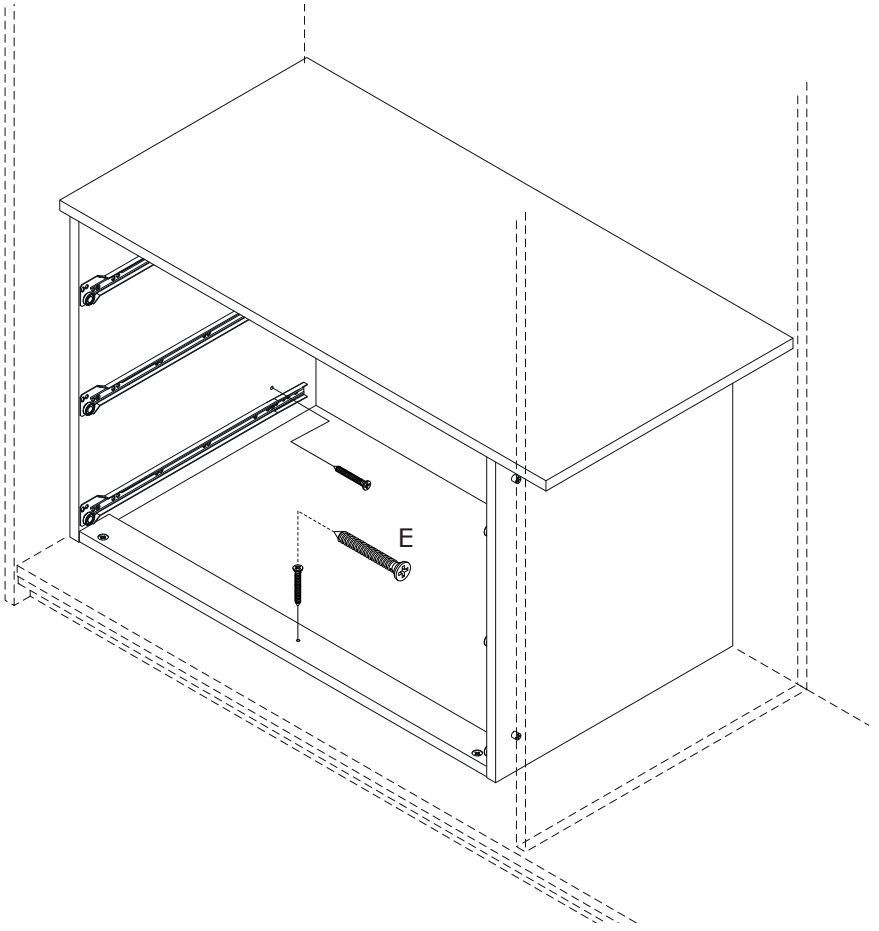
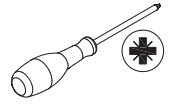

23

<p>K x 6</p>  <p>Ø7x45mm</p>	<p>A x 12</p>  <p>Ø8x2mm</p>	
---	---	---

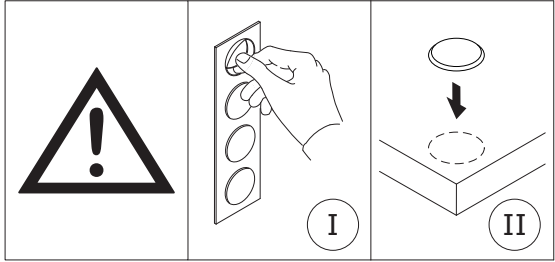
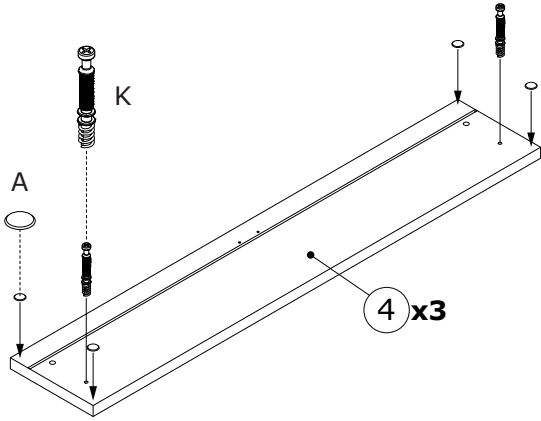

24

<p>H x 6</p>  <p>Ø15x10mm</p>	
---	--

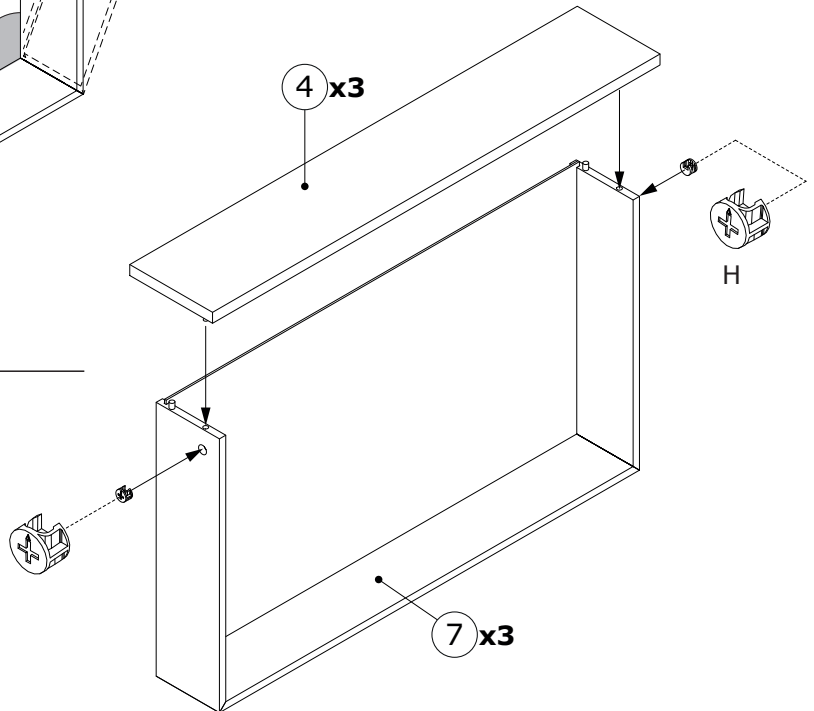
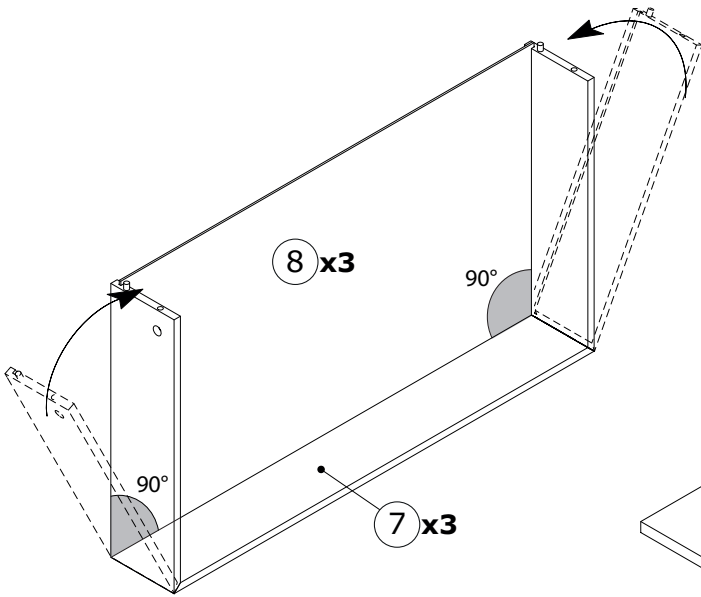

25

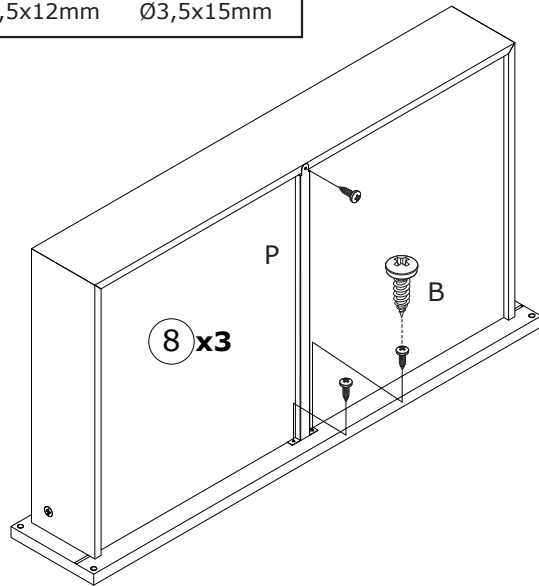
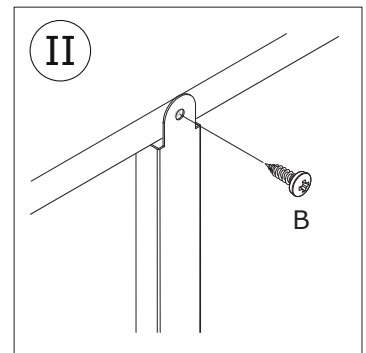
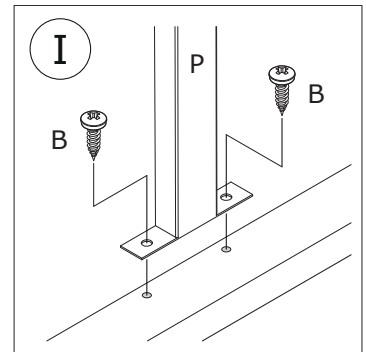
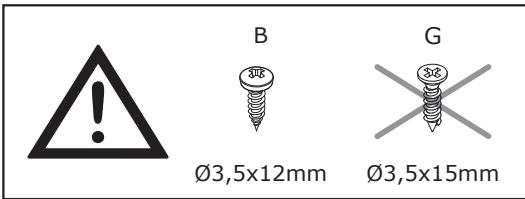
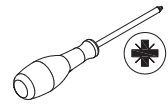
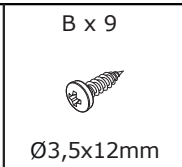
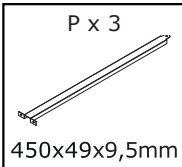

26

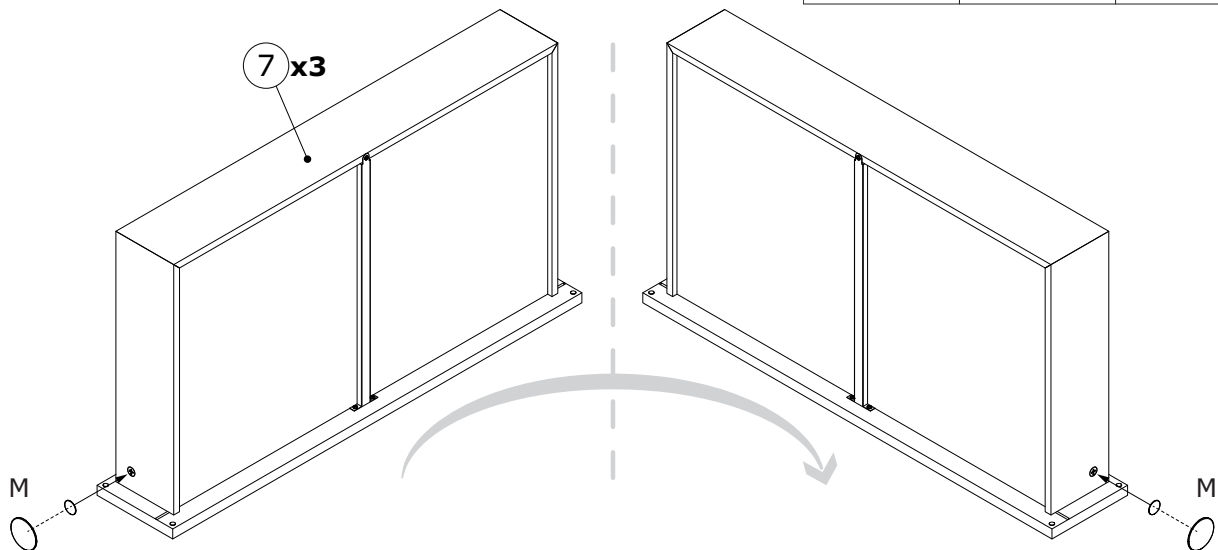
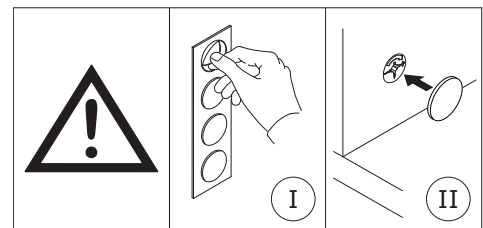
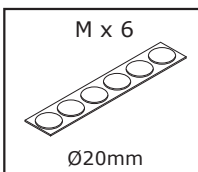

27

DL x 3  450mm	DR x 3  450mm	G x 12  Ø3x12mm	 
--	--	--	---

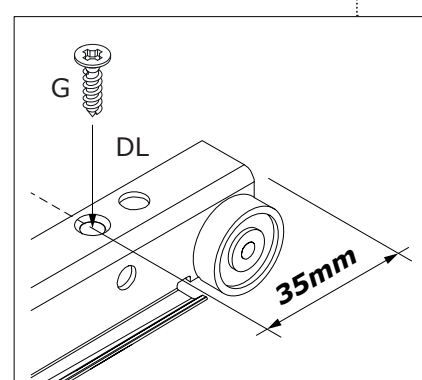
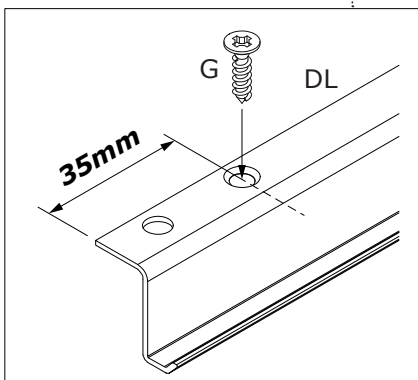
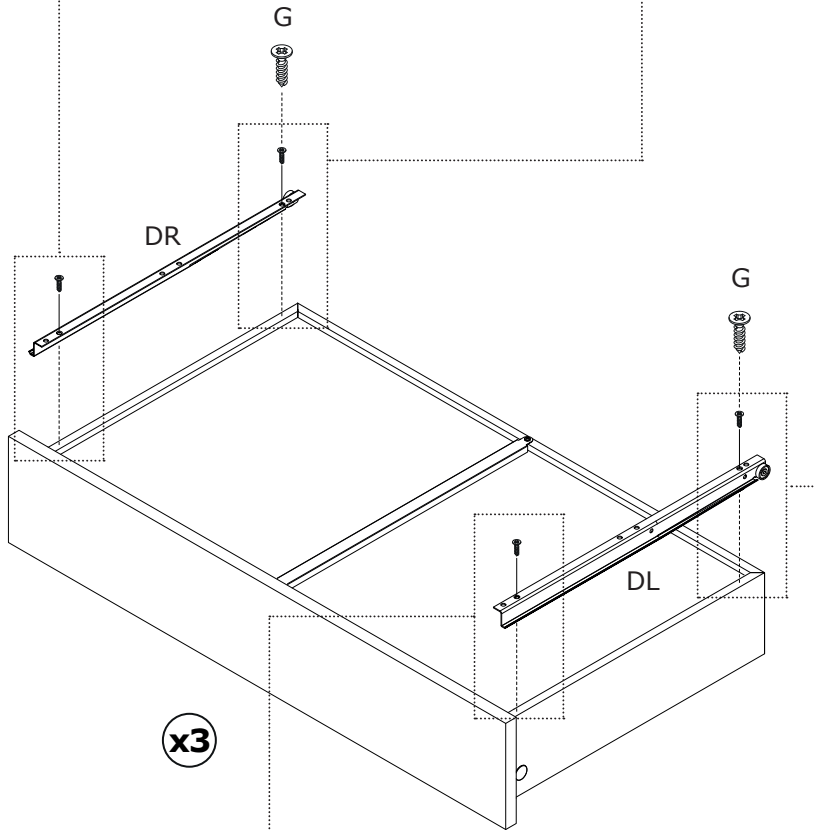
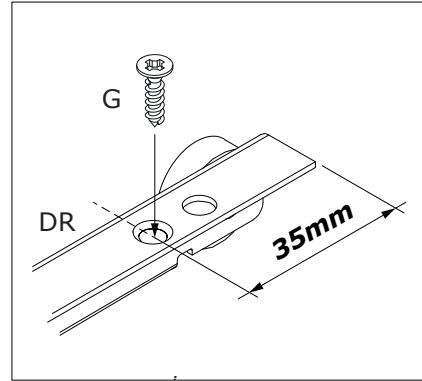
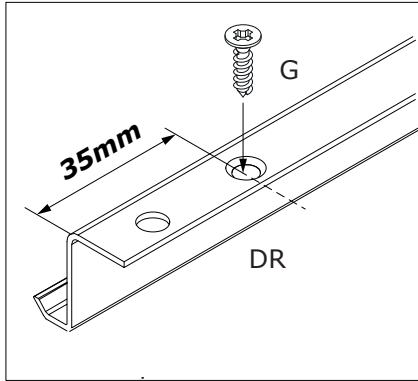

28

M x 2

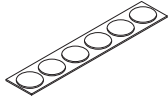

Ø20mm

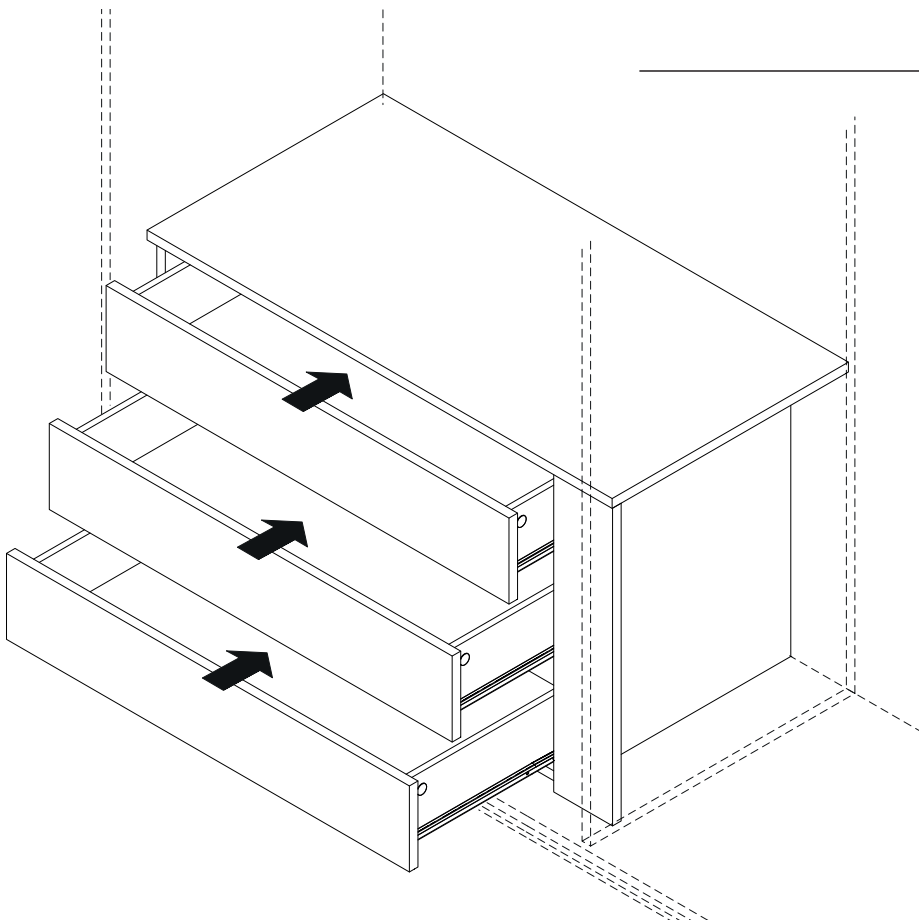
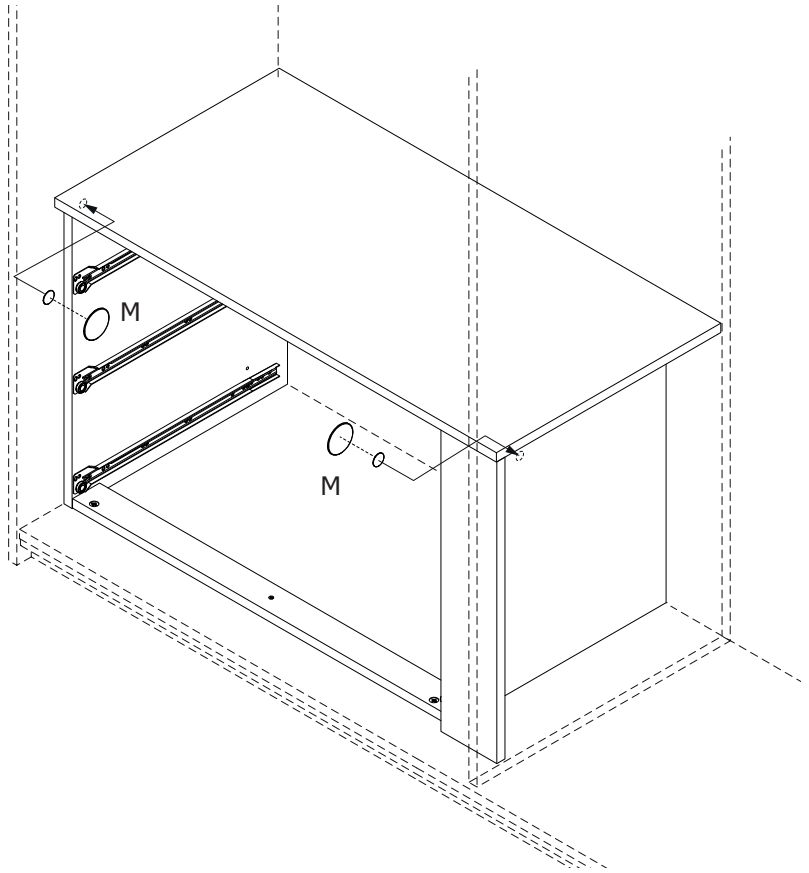

29

