

DAMHALE

707-216-1018

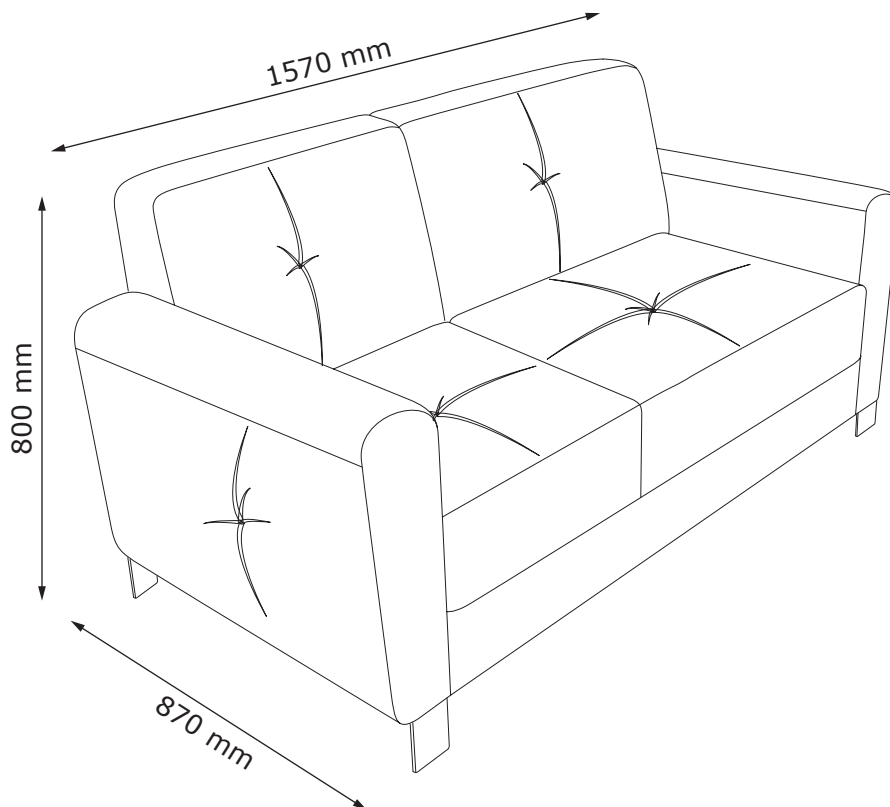

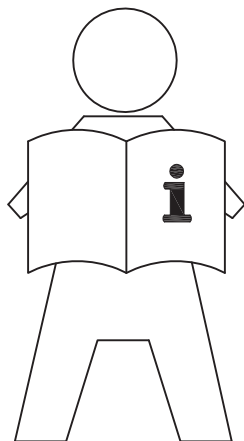

**EN: IMPORTANT INFORMATION!**

*Please read the entire manual carefully before starting to assemble and/or using this product. Follow the manual thoroughly and keep it for further reference.*

**FR: INFORMATIONS IMPORTANTES**

*Veillez lire attentivement l'ensemble du manuel avant de commencer à monter et/ou utiliser ce produit. Suivez rigoureusement le manuel et conservez-le pour toute consultation ultérieure.*

**LV: SVARĪGA INFORMĀCIJA!**

*Pirms šī izstrādājuma montāžas un/vai lietošanas uzsākšanas pilnībā izlasiet lietošanas pamācību. Stingri ievērojiet pamācības norādījumus un saglabājiet to turpmākai lietošanai.*

**LT: SVARBI INFORMACIJA!**

*Prieš pradėdami montuoti gaminį ir (arba) juo naudotis, prašome atidžiai perskaityti visą vadovą. Atidžiai skaitykite vadovą ir turėkite jį su savimi, kad galėtumėte toliau vadovautis jo nuorodomis.*

**EE: OLULINE TEAVE!**

*Enne kui alustate toote kokku panemist ja/või kasutamist, lugege see kasutusjuhend hoolikalt läbi. Järgige täpselt juhendis toodud juhiseid ja hoidke juhend alles.*

**BY: ВАЖНАЯ ИНФОРМАЦИЯ!**

*Внимательно и полностью прочитайте это руководство, прежде чем приступать к сборке или использованию этого изделия. Следуйте всем инструкциям этого руководства и сохраните его на будущее для справки.*

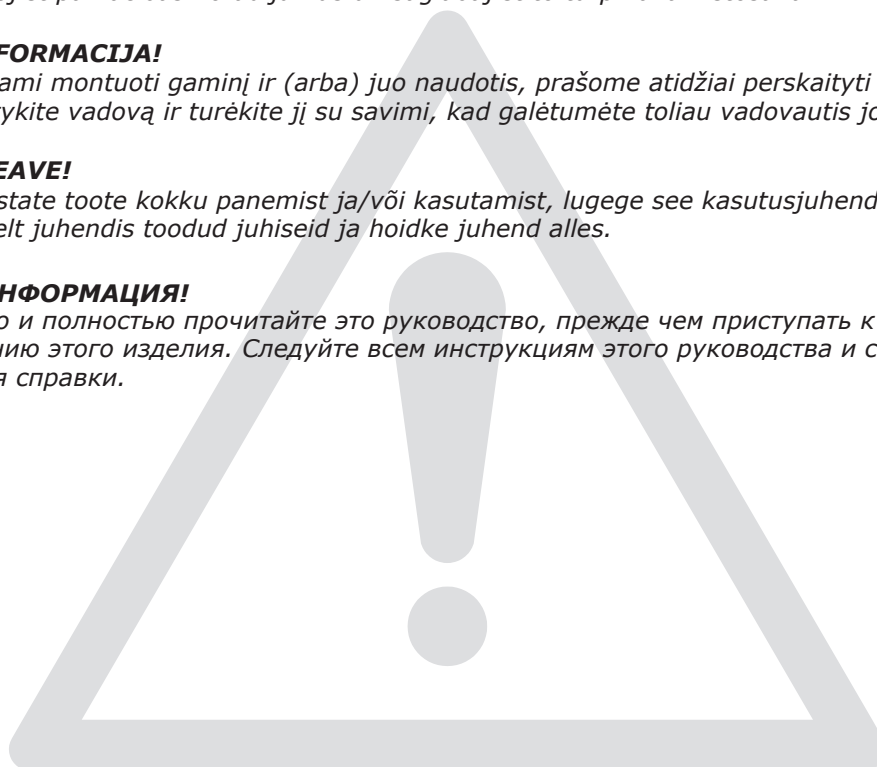

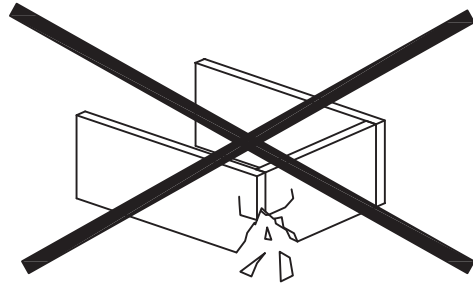
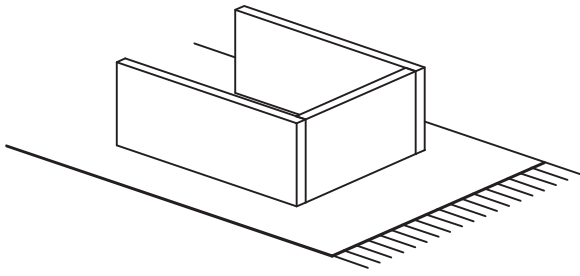

**EN: WARNING TO AVOID SCRATCHES!**

*In order to avoid scratching this furniture should be assembled on a soft layer - could be a rug.*

**FR: AVERTISSEMENT POUR ÉVITER LES RAYURES**

*Afin d'éviter les rayures, ce meuble doit être monté sur une surface souple (un tapis, par exemple).*

**LV: BRĪDINĀJUMS PAR SKRĀPĒJUMIEM!**

*Lai nesaskrāpētu šo izstrādājumu, veiciet montāžu uz mīkstas pamatnes, piemēram, paklāja.*

**LT: ĮSPĖJIMAS, KAD IŠVENGTUMĖTE ĮBRĖŽIMŲ!**

*Šio baldo nesubraižysite, jei jį surinksite ant švelnaus paviršiaus, pavyzdžiui, kilimo.*

**EE: HOIATUS KRIIMUSTUSTE VÄLTIMISEKS!**

*Kriimustuste tekkimise vältimiseks mööblile tuleb see kokku panna pehmel pinnal, nt kaltsuvaibal.*

**BY: ПРЕДУПРЕЖДЕНИЕ ОТНОСИТЕЛЬНО ЦАРАПИН!**

*Во избежание нанесения царапин, сборку этой мебели необходимо выполнять на мягкой поверхности, например на ковре.*

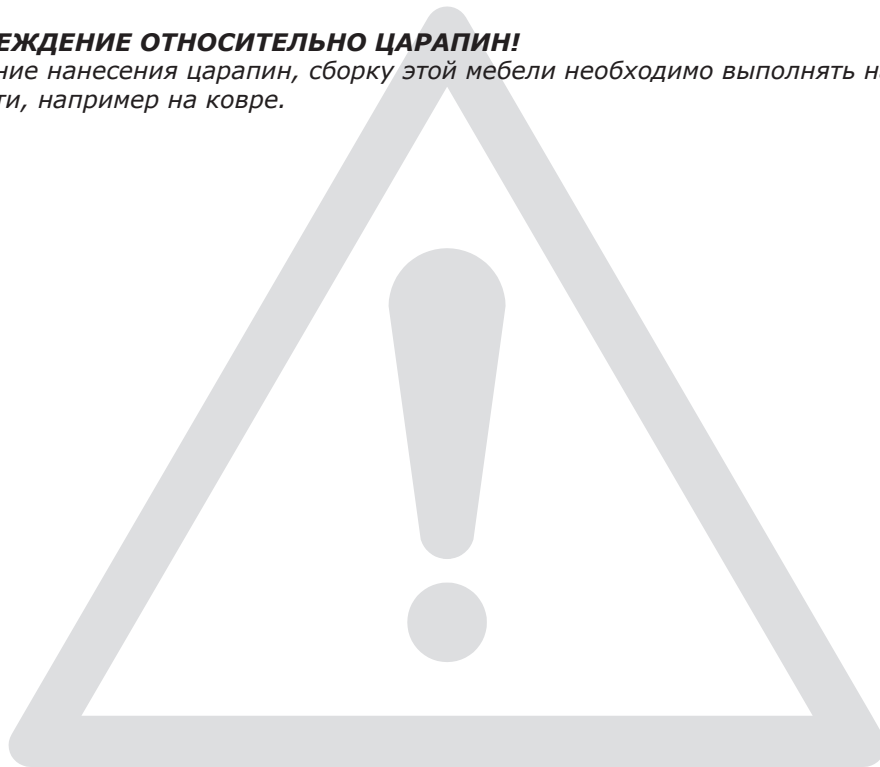

**EN: IMPORTANT!**

*It is important that any product which is assembled using any kind of screw is re-tightened 2 weeks after assembly, and once every 3 months - in order to assure stability through-out the lifespan of the product.*

**FR: IMPORTANT**

*Il est important que tout produit monté à l'aide de vis soit resserré 2 semaines après son montage, puis tous les 3 mois, afin de garantir sa stabilité durant tout son cycle de vie.*

**LV: SVARĪGI!**

*Ir svarīgi, lai jebkuram produktam, kas tiek uzstādīts ar jebkādu skrūvju palīdzību, skrūves tiktu atkārtoti pievilktas 2 nedēļas pēc montāžas, pēc tam – reizi 3 mēnešos, tā nodrošinot stabilitāti visā izstrādājuma kalpošanas laikā.*

**LT: SVARBU!**

*Bet kokį varžtais tvirtinamą gaminį 2 savaites po surinkimo bei kas 3 mėnesius reikia papildomai suveržti – taip užtikrinamas naudojamo gaminio stabilumas.*

**EE: TÄHTIS!**

*Oluline on, et toote kruvisid pingutataks 2 nädalat pärast kokkupanekut ja seejärel iga 3 kuu järel, et tagada stabiilsus kogu toote eluea jooksul.*

**BY: ВАЖНО!**

*В любом изделии, собранном с использованием винтов любого типа, необходимо через 2 недели после сборки и в дальнейшем каждые 3 месяца подтягивать винты, чтобы обеспечить прочность изделия в течение срока эксплуатации.*



**EN: MATERIALS MADE OF PU/BONDED LEATHER!**

*Products covered in PU/Bonded leather, must not be treated with leather care products, since they will destroy the PU/ Bonded leather.*

**FR: MATÉRIAUX COMPOSÉS DE PU/CUIR RECONSTITUÉ**

*Les produits recuverts de PU/cuir reconstitué ne doivent pas être traités à l'aide de produits d'entretien du cuir, car ces derniers endommageraient le PU/cuir reconstitué.*

**LV: MATERIĀLI NO PU/ PĀRSTRĀDĀTAS ĀDAS!**

*Izstrādājumiem ar PU/pārstrādātas ādas pārklājumu nedrīkst izmanto ādas kopšanas līdzekļus, jo tie sabojās PU/pārstrādāto ādu.*

**LT: MEDŽIAGOS PAGAMINTOS IŠ PU /PERDIRBTOS ODOS!**

*PU arba perdirbta oda aptrauktų gaminių nevalykite odos priežiūros priemonėmis, nes, tikėtina, kad jos sugadins PU arba perdirbtą odą.*

**EE: PU-st/KOKKUPRESSITUD NAHAST VALMISTATUD MATERJALID!**

*PU-ga/kokkupressitud nahaga kaetud tooteid ei tohi töödelda nahahoodustoodetega, sest viimased kahjustavad PU-d/kokkupressitud nahka.*

**BY(RU): МАТЕРИАЛЫ ИЗ ПОЛИУРЕТАНА / ИСКУССТВЕННОЙ КОЖИ!**

*Изделия с покрытием из полиуретана или искусственной кожи нельзя чистить средствами для ухода за натуральной кожей, они испортят покрытие.*

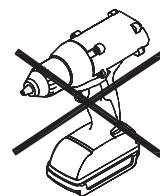

A × 12

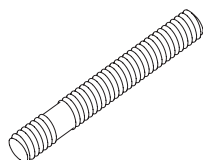

M6×100 mm

B × 12



Ø6/Ø20 mm

C × 12



M6 mm

D × 12

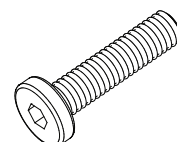

M8×25 mm

E × 1

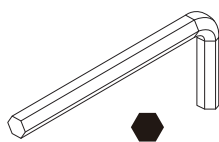

5 mm

F × 1

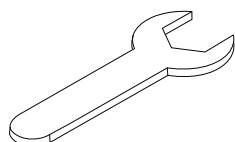

M10×88 mm

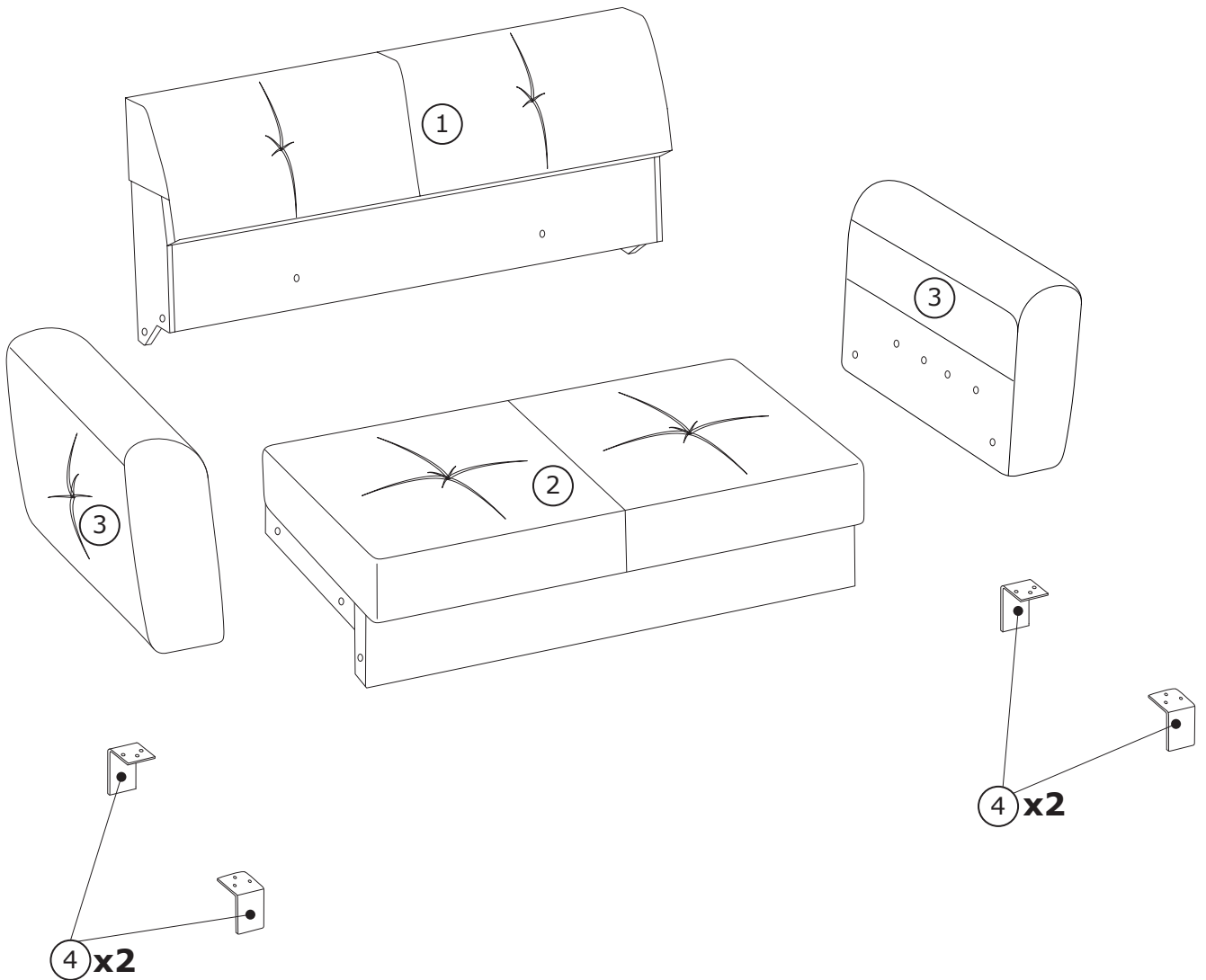

**Box 1/2:**

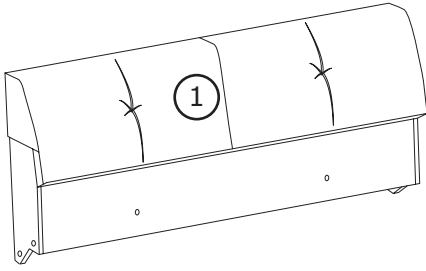

1200×685×320mm

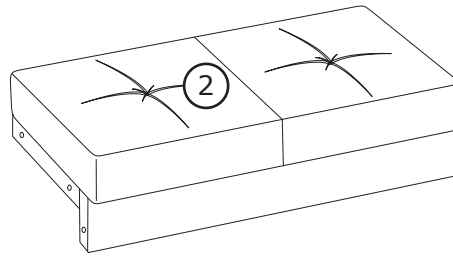

1210×620×315mm

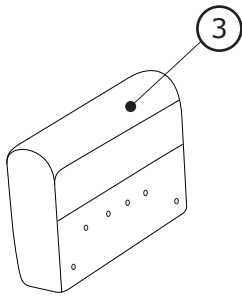

850×465×200mm

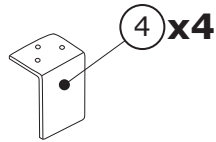

90×120×2.5mm

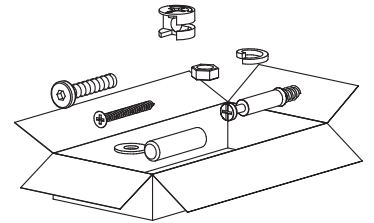

**Box 2/2:**

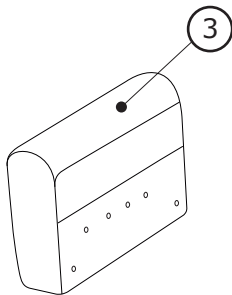

850×465×200mm



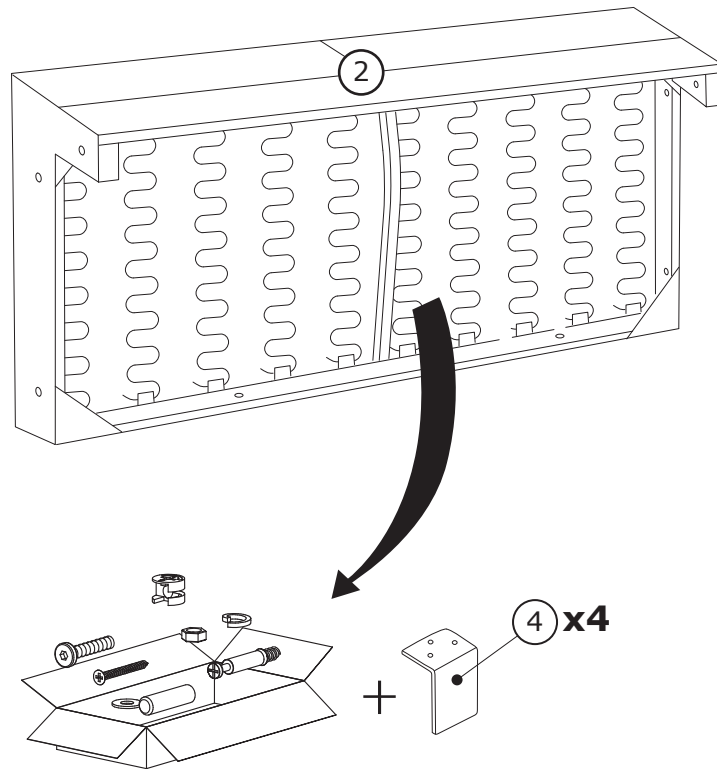

1

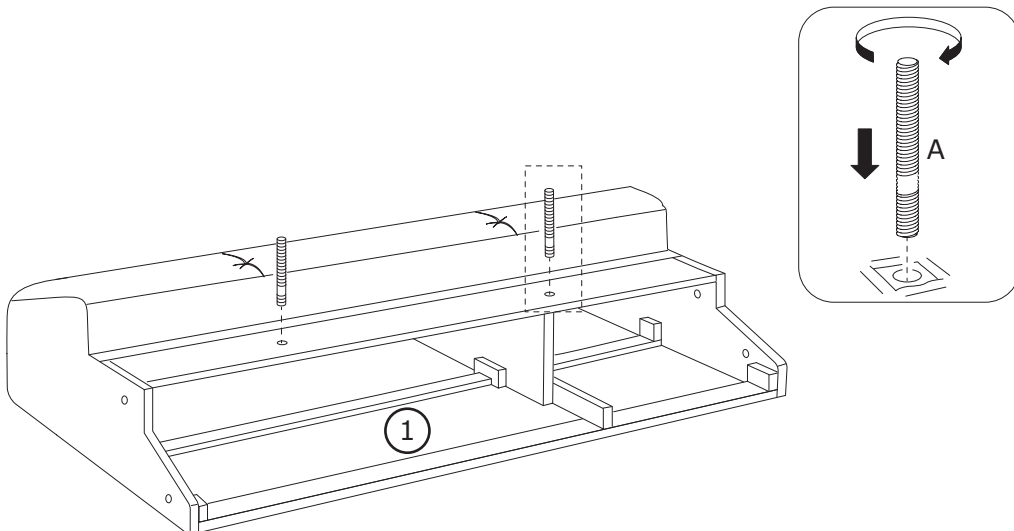
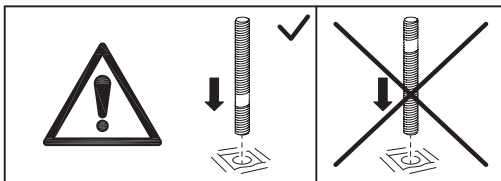

2

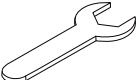

3

B × 2  Ø6/Ø20 mm	C × 2  M6 mm	F × 1  M10×88 mm	
---	---	---	--

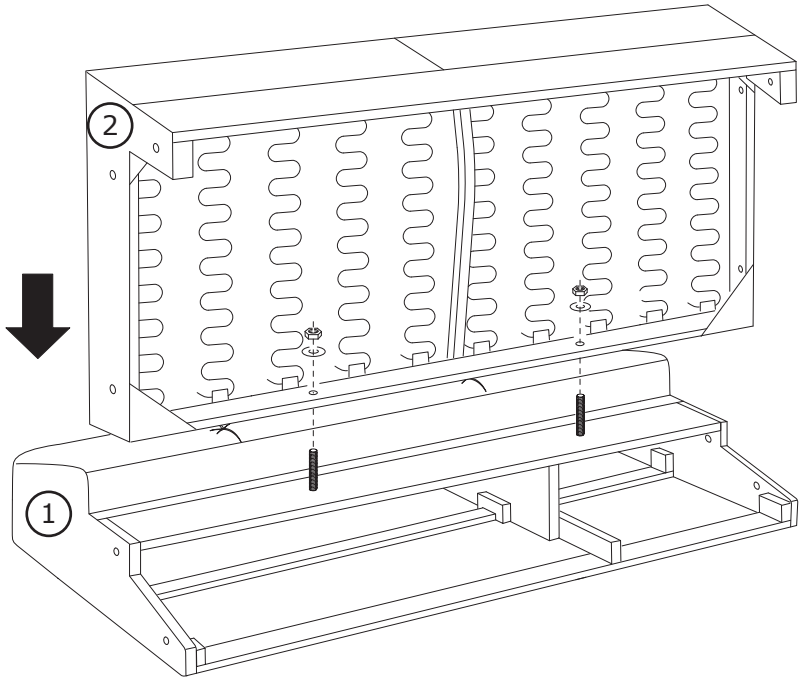
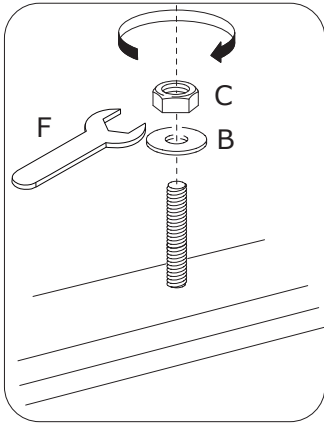

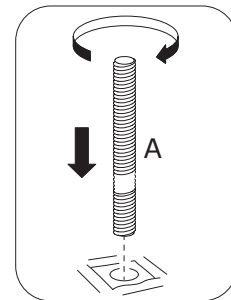
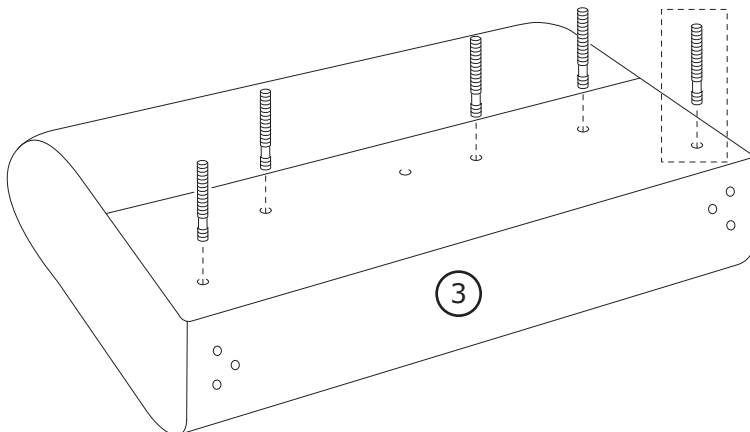
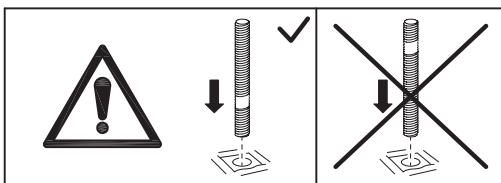

4

A × 5  M6×100 mm	
---	--

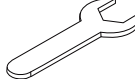

5

<p>B × 5</p>  <p>Ø6/Ø20 mm</p>	<p>C × 5</p>  <p>M6 mm</p>	<p>F × 1</p>  <p>M10×88 mm</p>	
---	---	---	--

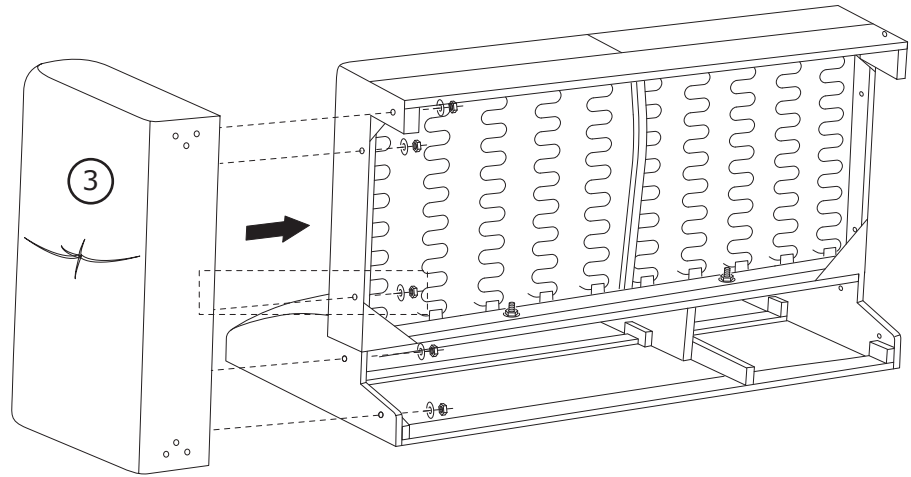
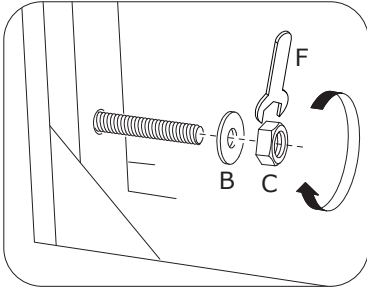

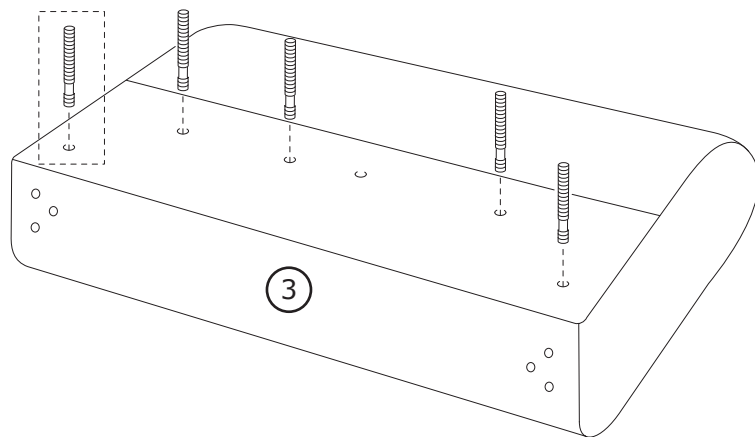
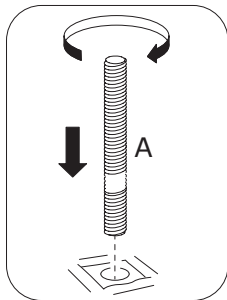
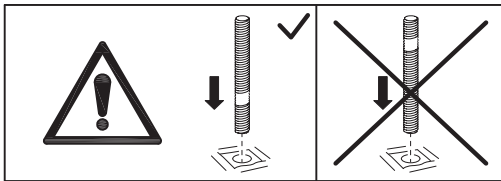

6

<p>A × 5</p>  <p>M6×100 mm</p>	
---	--



7

B × 5  Ø6/Ø20 mm	C × 5  M6 mm	F × 1  M10×88 mm	
---	---	---	--

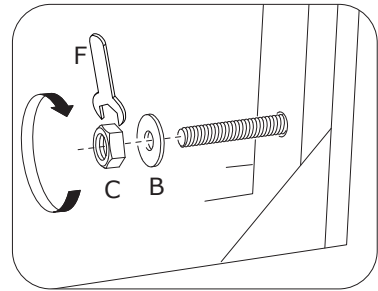
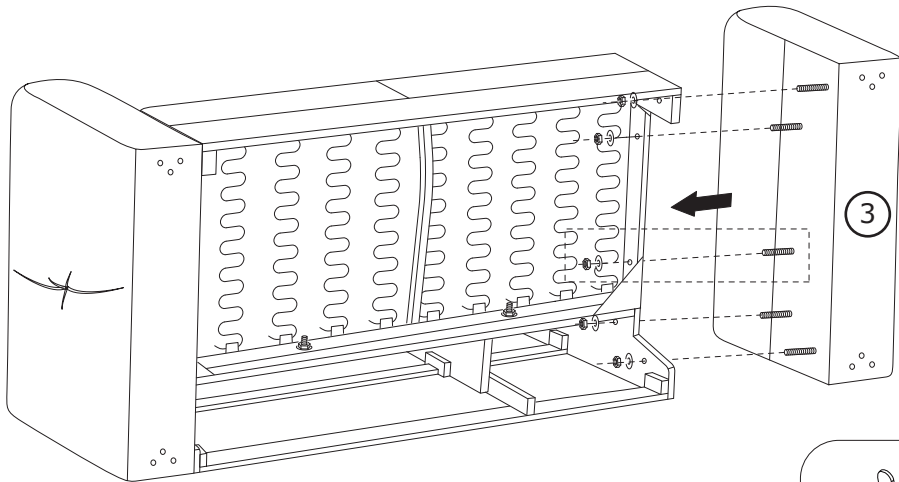

8

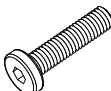
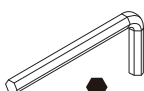
D × 12  M8×25 mm	E × 1  5 mm	
---	--	--

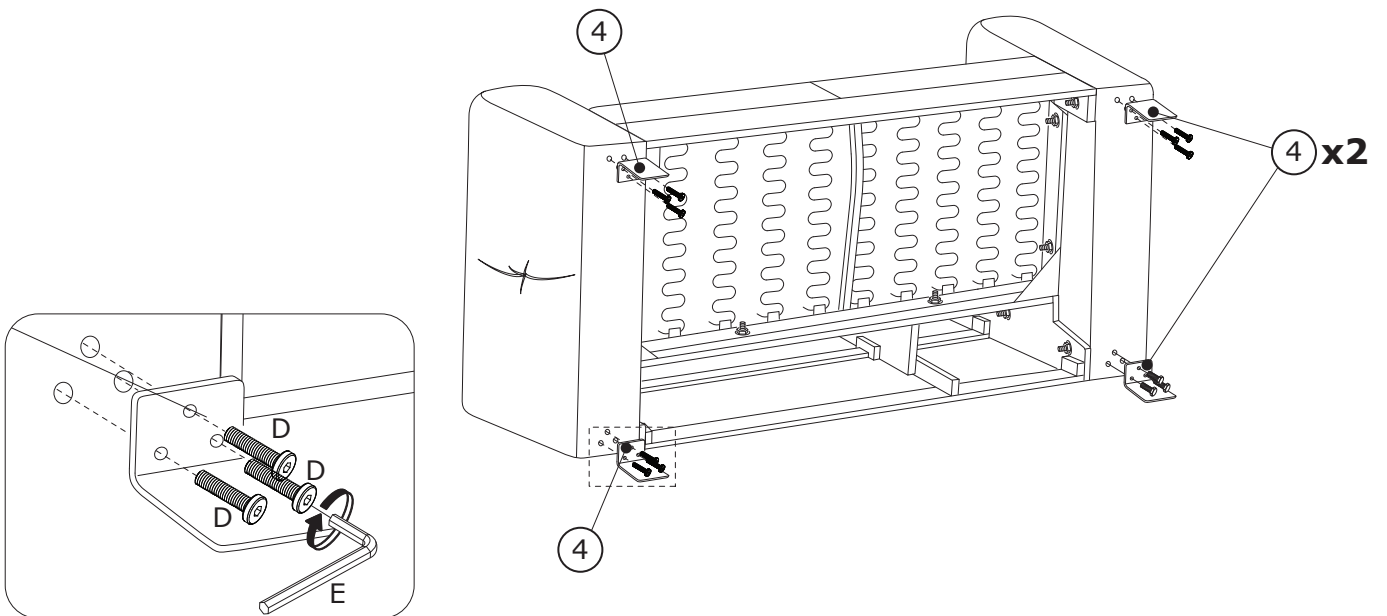

9

